

**UNIT TYPE : A (1-BEDROOM)**

AREA : 41 Sqm (441 Sq ft)

(Inclusive of AC Ledge: 3 Sqm & Balcony: 4 Sqm)

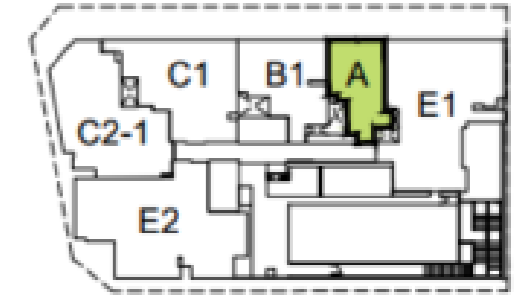

**3<sup>rd</sup> Floor**

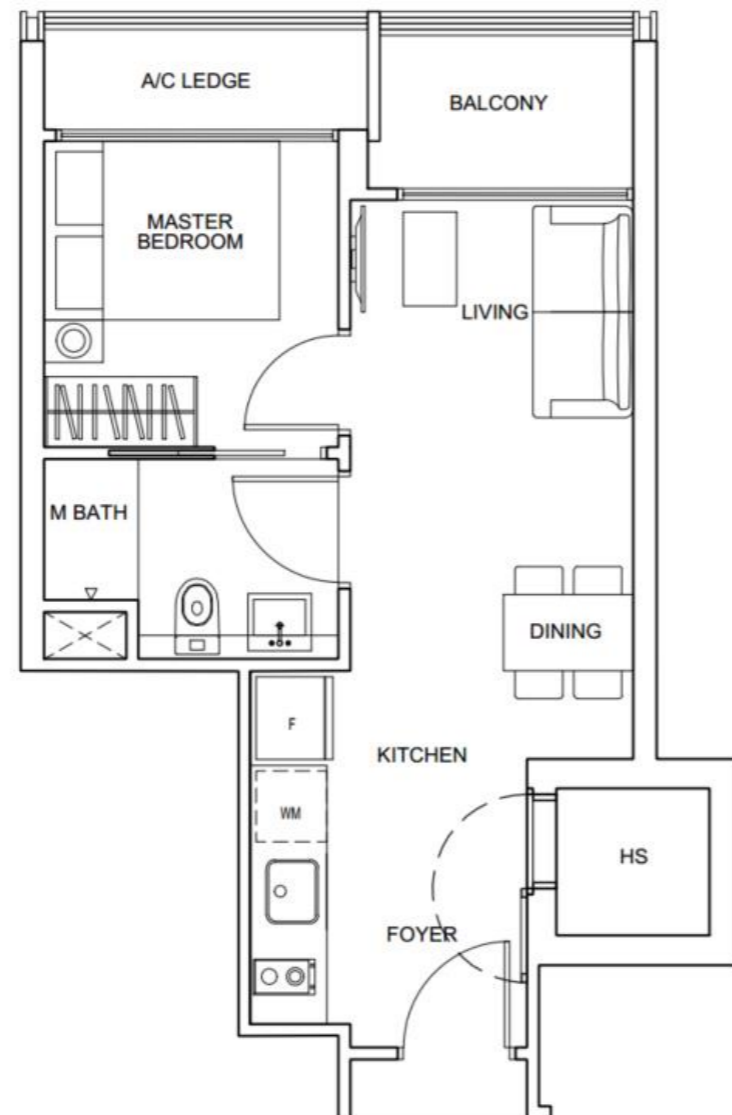

ZYANYA

# UNIT TYPE

UNIT TYPE : **B1 (2-BEDROOM)**

AREA : 57 Sqm (614 Sq ft)

(Inclusive of AC Ledge: 3 Sqm & Balcony: 4 Sqm)

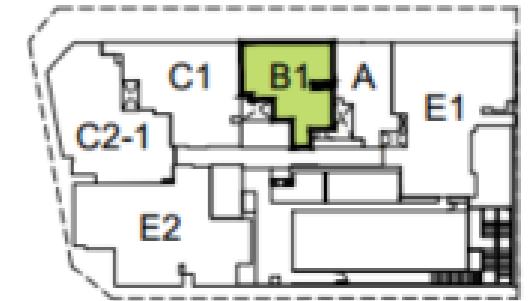
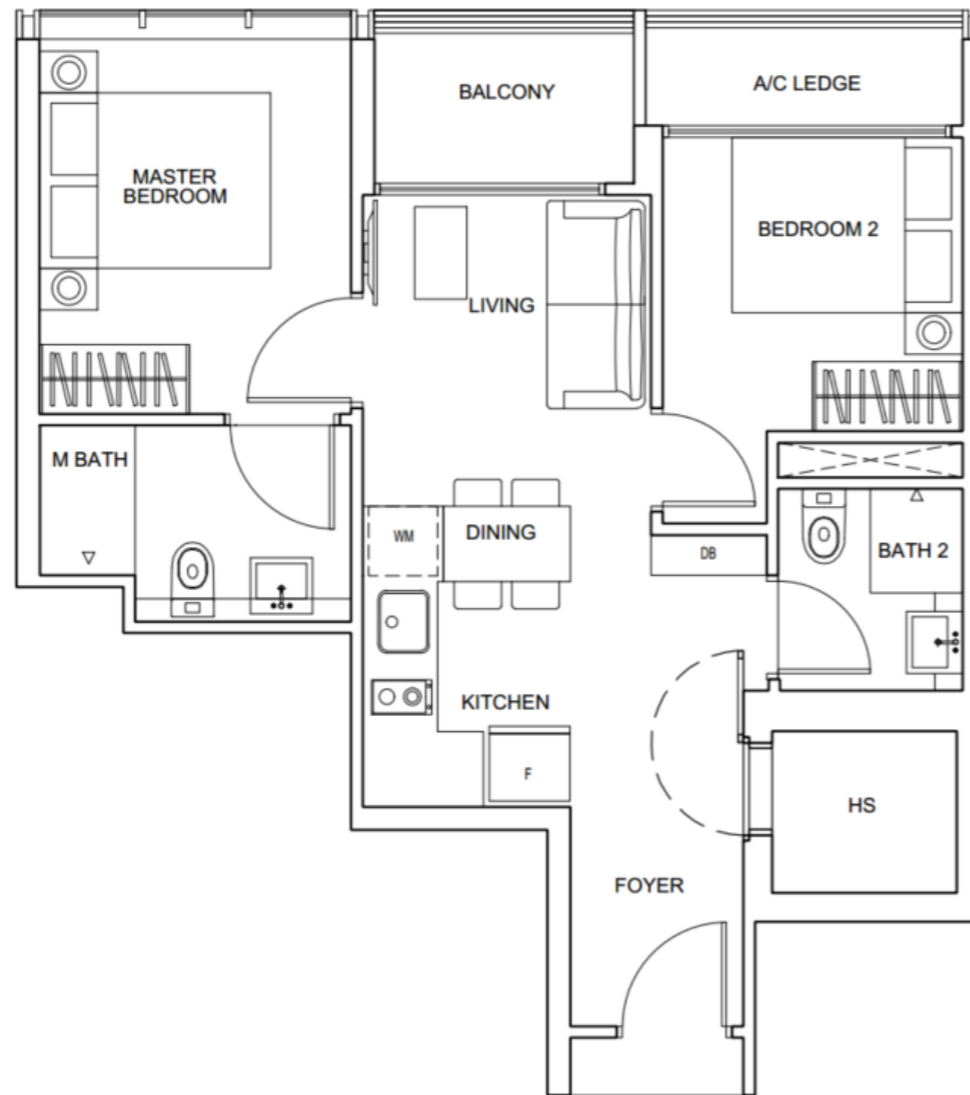

**3<sup>rd</sup> Floor**

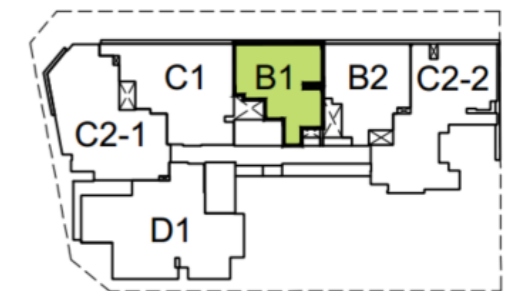

**4th Floor to 7th Floor**

UNIT TYPE : **B2 (2-BEDROOM)**

AREA : 60 Sqm (646 Sq ft)

(Inclusive of AC Ledge: 3 Sqm & Balcony: 4 Sqm)

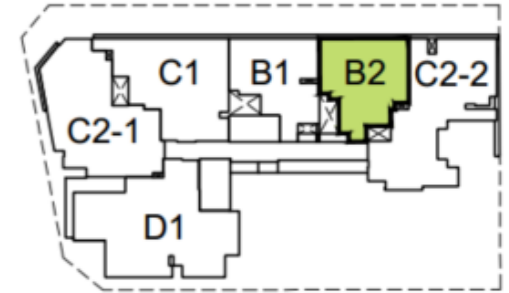

**4th Floor to 7th Floor**

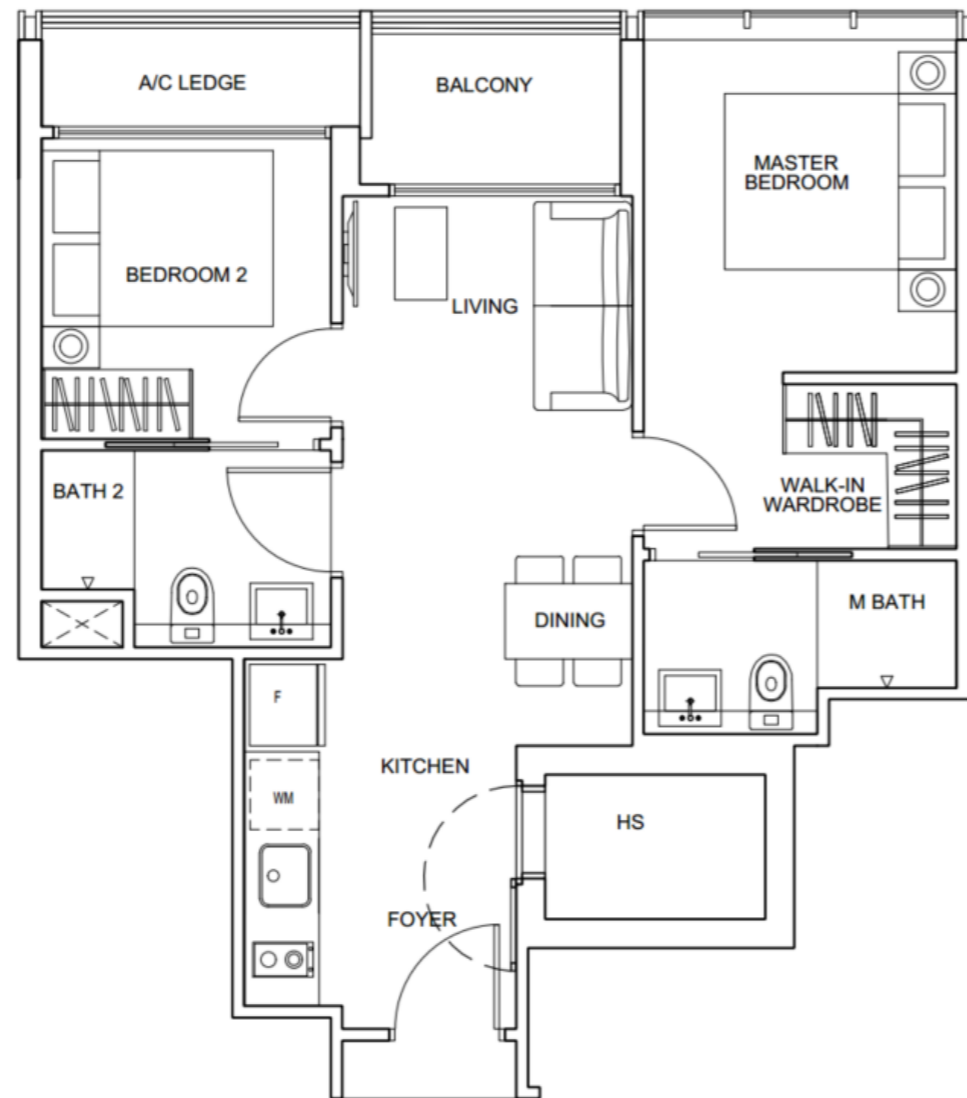

**UNIT TYPE : C1 (3-BEDROOM)**

AREA : 83 Sqm (893 Sq ft)

(Inclusive of AC Ledge: 5 Sqm & Balcony: 5 Sqm)

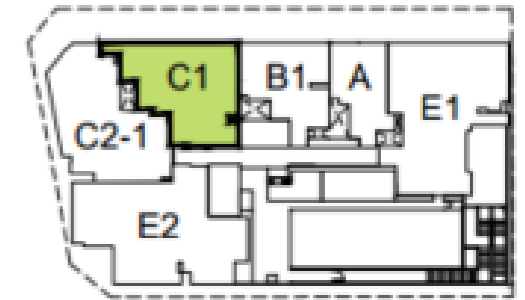
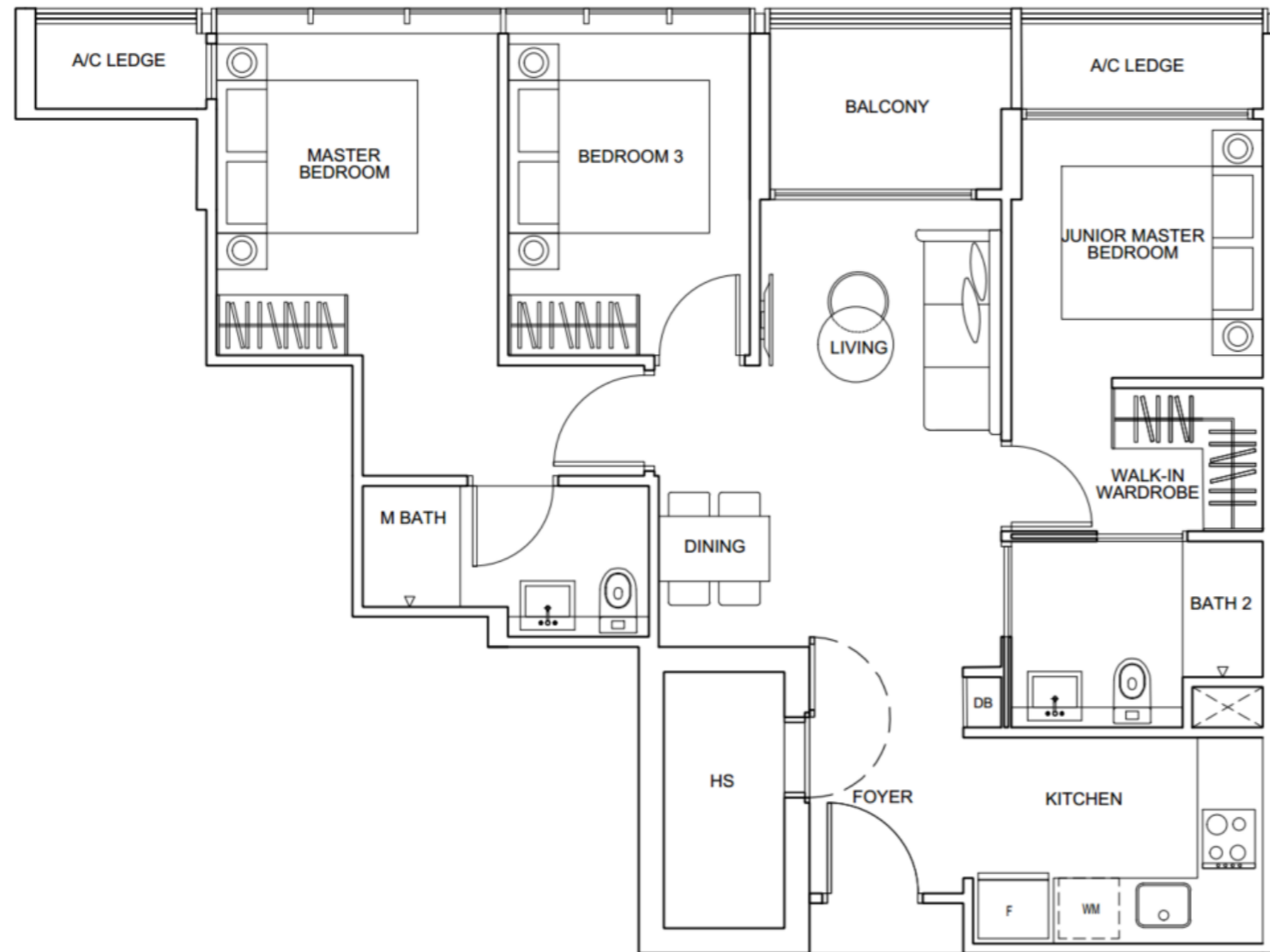

**3<sup>rd</sup> Floor**

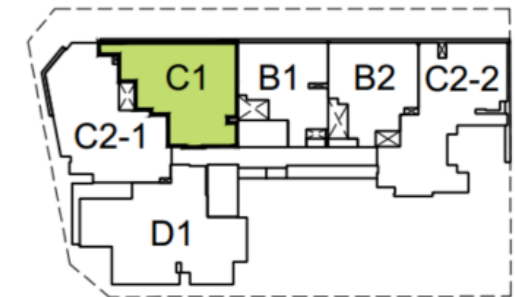

**4th Floor to 7th Floor**



**UNIT TYPE : C2-1 (3-BEDROOM + STUDY) DUAL KEY**

AREA : 95 Sqm (1023 Sq ft)

(Inclusive of AC Ledge: 4 Sqm & Balcony: 6 Sqm)

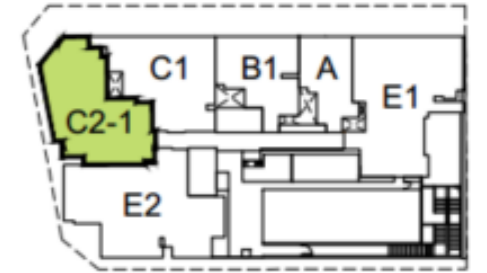
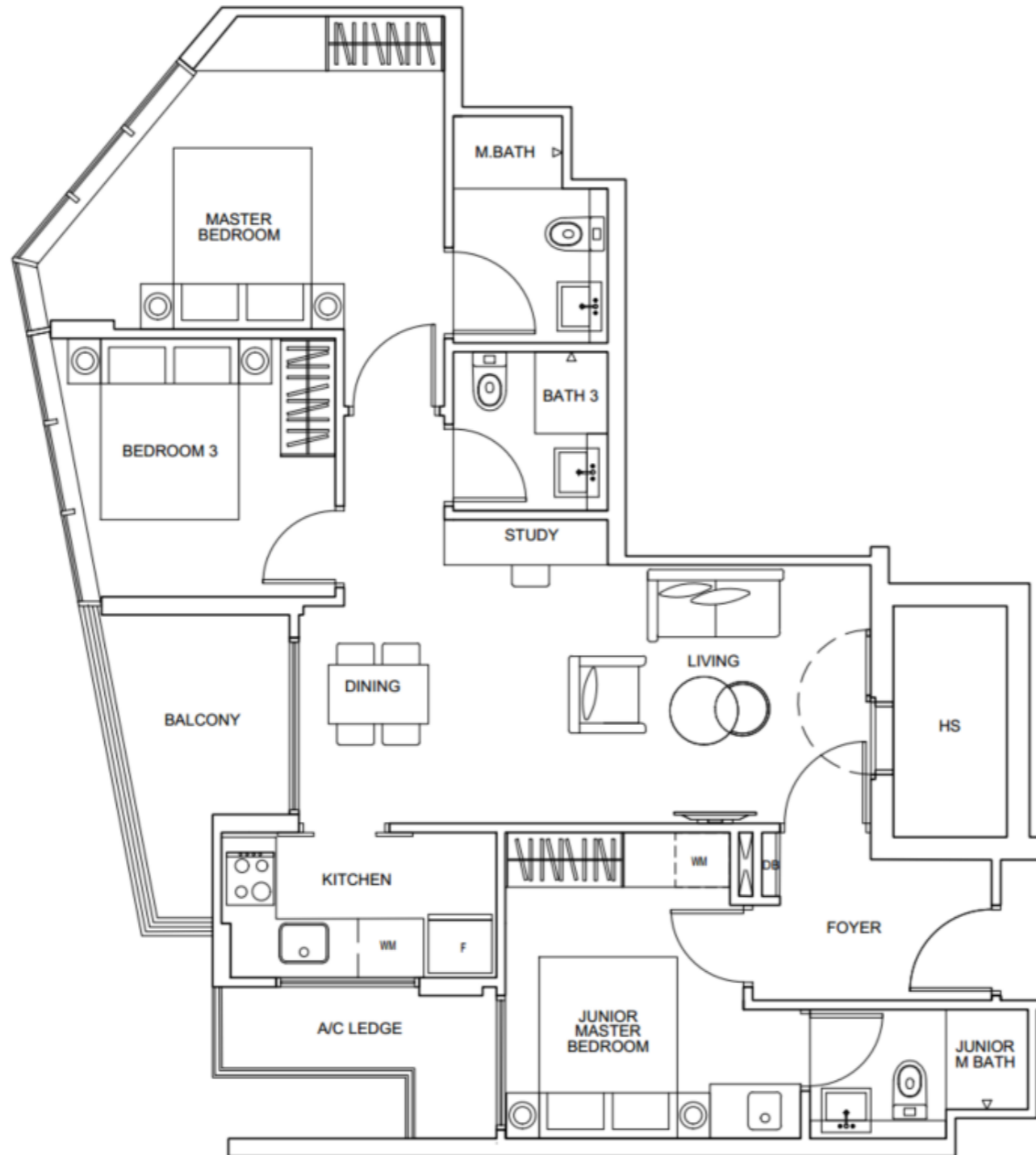

**3<sup>rd</sup> Floor**

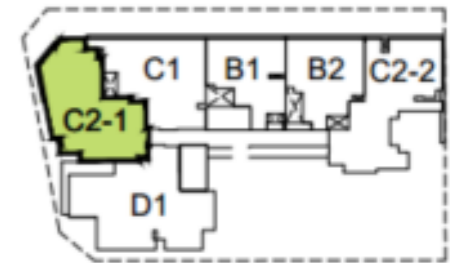

**4th Floor to 7th Floor**

## UNIT TYPE : C2-2 (3-BEDROOM + STUDY)

AREA : 97 Sqm (1044 Sq ft)

(Inclusive of AC Ledge: 8 Sqm & Balcony: 6 Sqm)

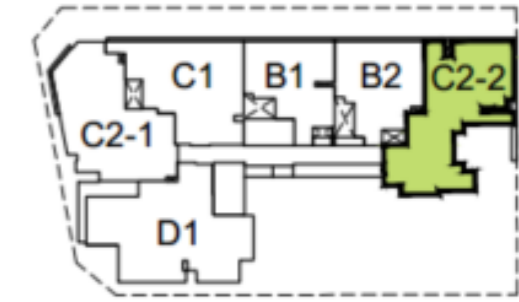
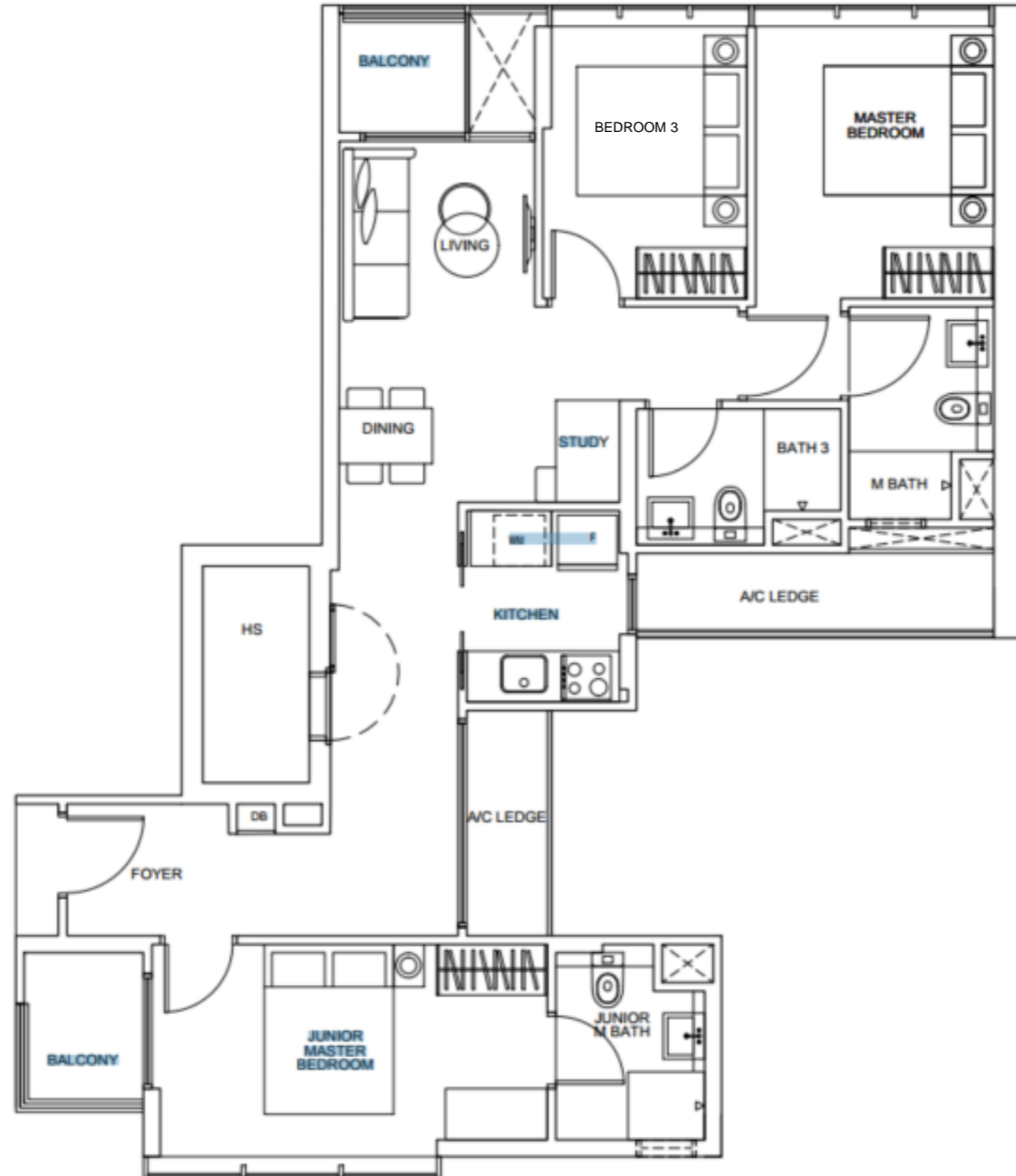

4th Floor to 7th Floor

# UNIT TYPE

UNIT TYPE : **D1 (4-BEDROOM)**

AREA : 111 Sqm (1195 Sq ft)

(Inclusive of AC Ledge: 5 Sqm & Balcony: 11 Sqm)

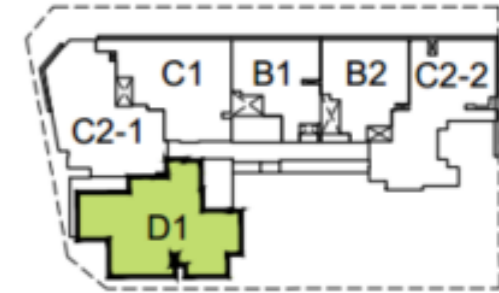

4th Floor to 7th Floor

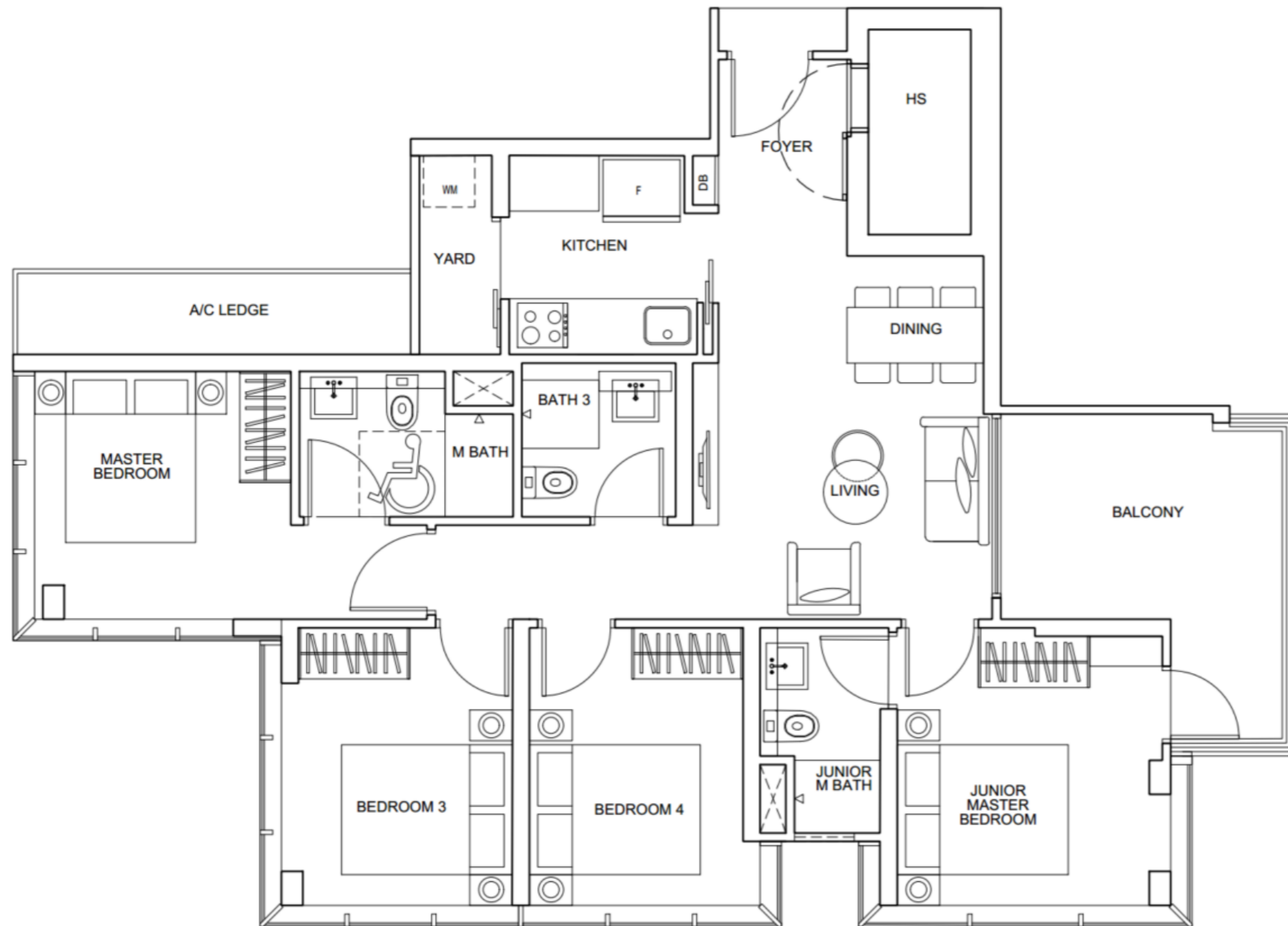



# UNIT TYPE

UNIT TYPE : **PH1 (4-BEDROOM)**

AREA : 114 Sqm (1227 Sq ft)

(Inclusive of AC Ledge: 7 Sqm & Balcony: 8 Sqm))

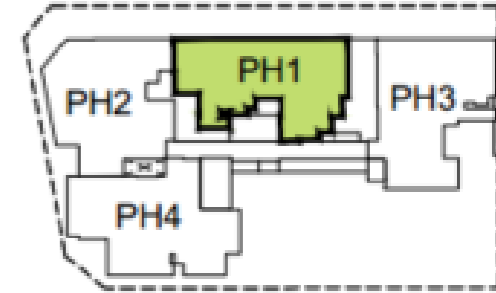

8<sup>th</sup> Floor

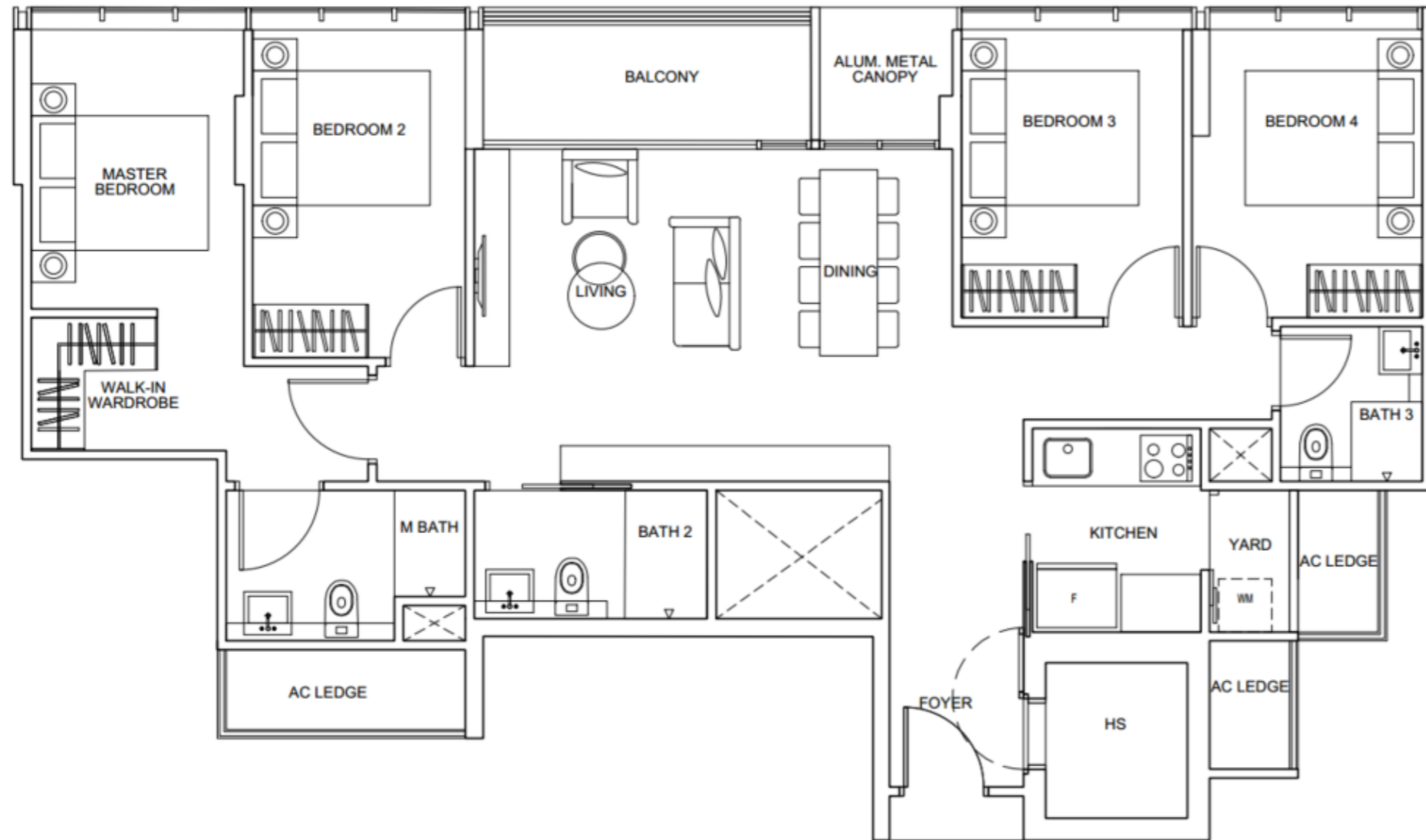



# UNIT TYPE

UNIT TYPE : **PH2 (4-BEDROOM)**

AREA : 121 Sqm (1302 Sq ft)

(Inclusive of AC Ledge: 10 Sqm & Balcony: 8 Sqm)

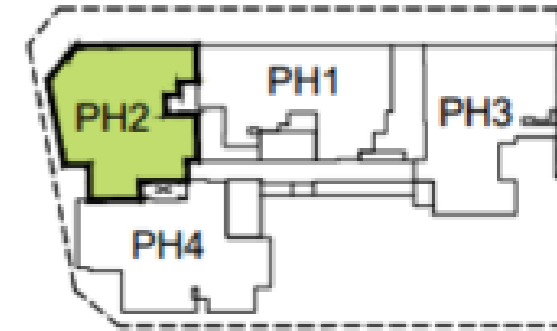
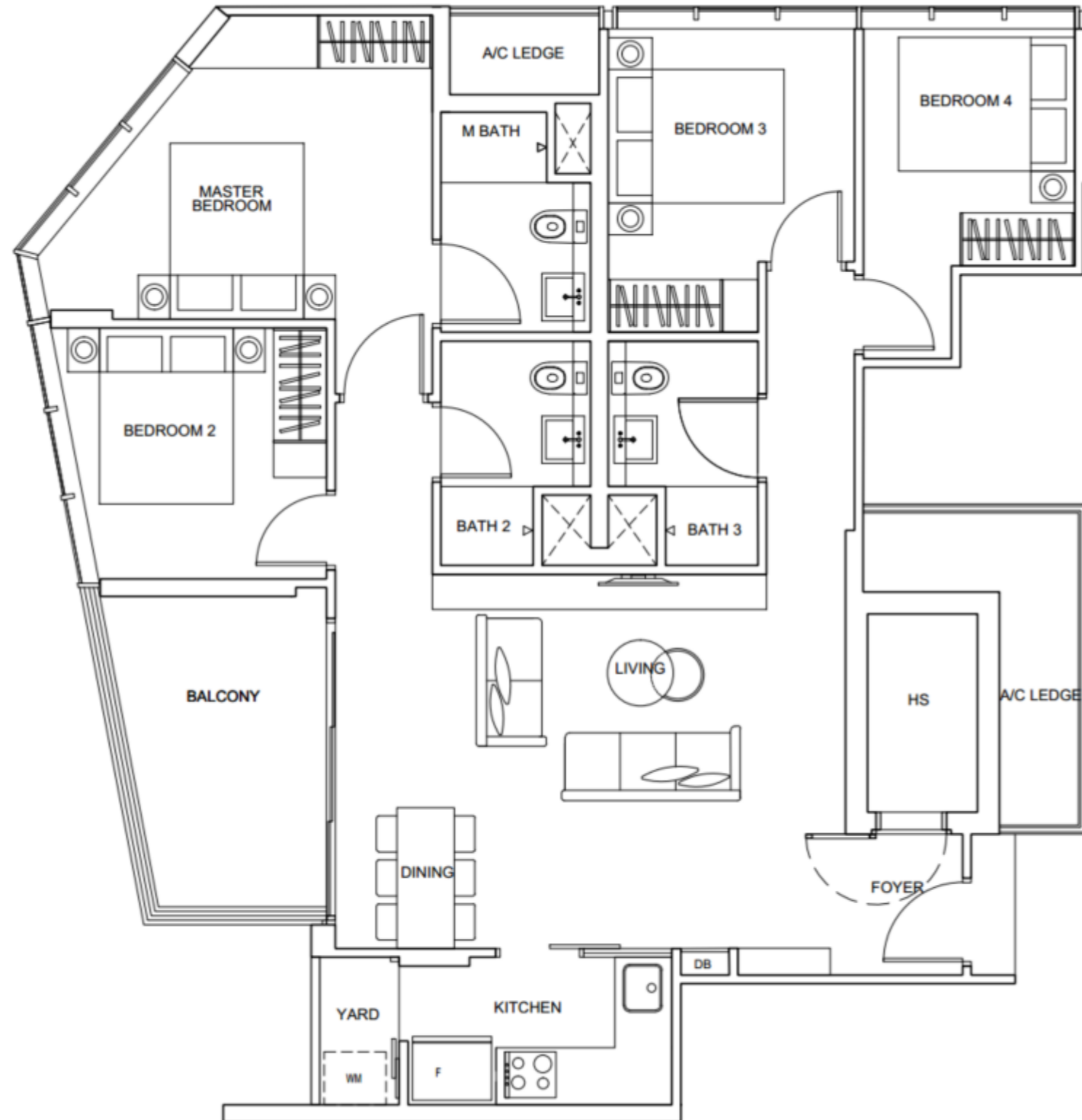

8<sup>th</sup> Floor

UNIT TYPE : **E1 (4-BEDROOM + STUDY)**

AREA : 121 Sqm (1302 Sq ft)

(Inclusive of AC Ledge: 7 Sqm & Balcony: 9 Sqm)

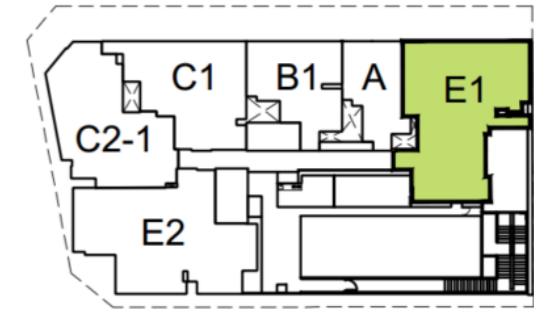

**3<sup>rd</sup> Floor**

# UNIT TYPE

UNIT TYPE : PH3 (4-BEDROOM + STUDY)

AREA : 121 Sqm (1302 Sq ft)

(Inclusive of AC Ledge: 7 Sqm & Balcony: 9 Sqm)

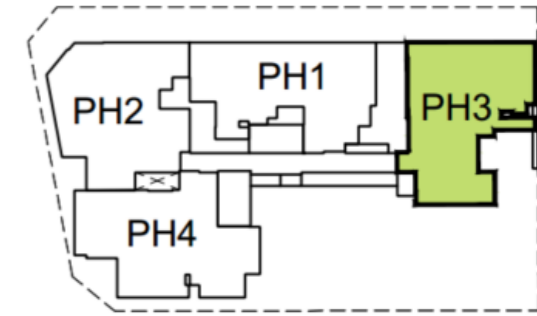

8<sup>th</sup> Floor



# UNIT TYPE

UNIT TYPE : **E2 (4-BEDROOM) or PH4 (4-BEDROOM)**

AREA : 122 Sqm (1313 Sq ft)

(Inclusive of AC Ledge: 6 Sqm & Balcony: 11 Sqm)

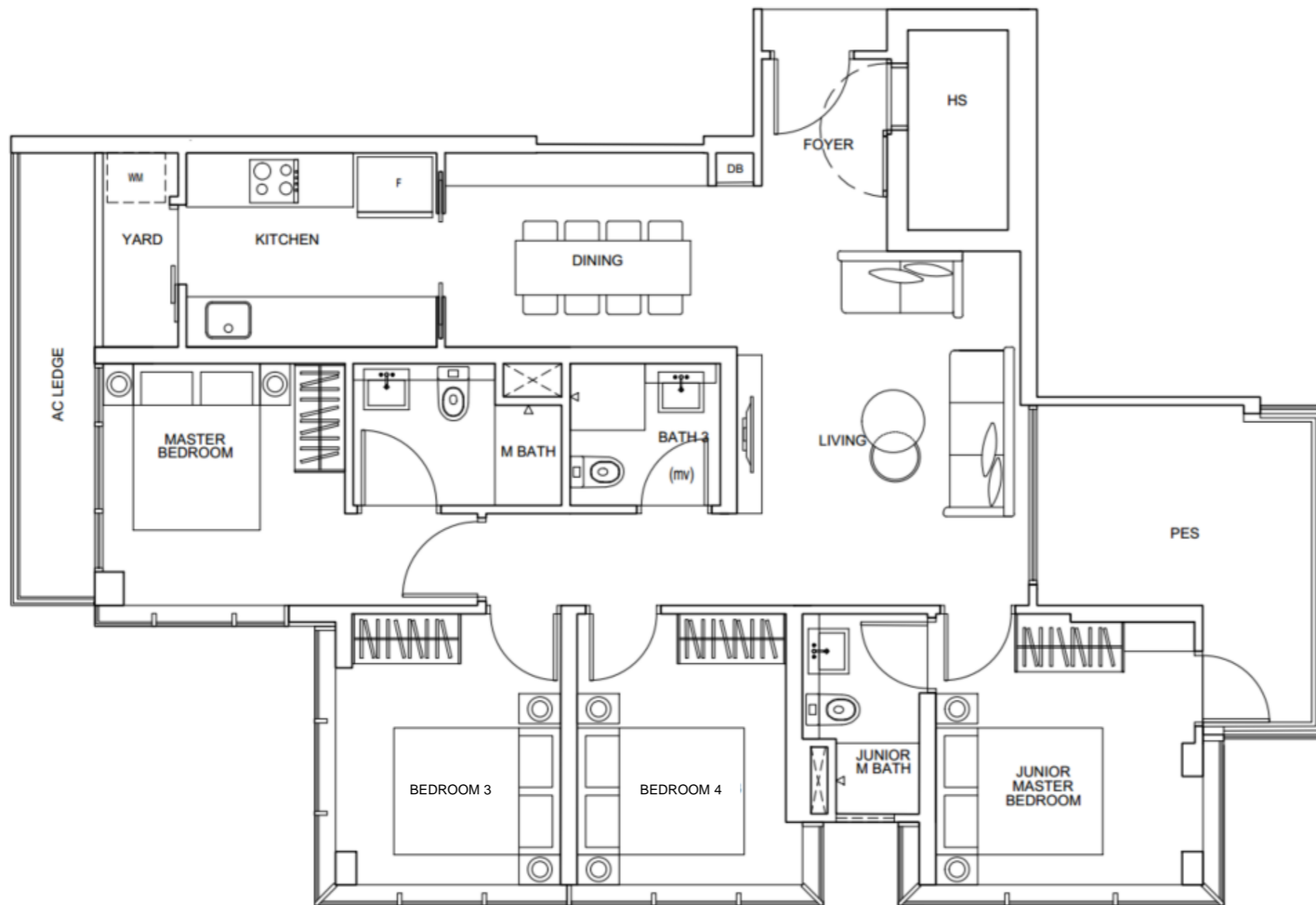

3<sup>rd</sup> Floor

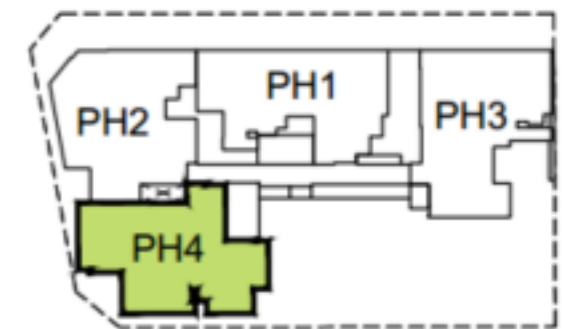

8<sup>th</sup> Floor