

1-Bedroom

Type A1

50 sqm / 538 sq ft
#02-12 to #08-12, #09-12*, #10-12*

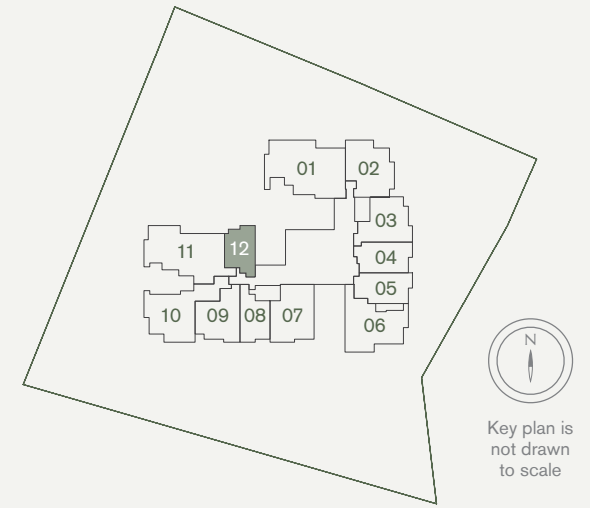

ODD FLOOR

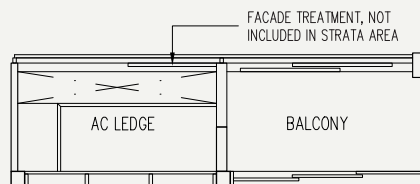

EVEN FLOOR

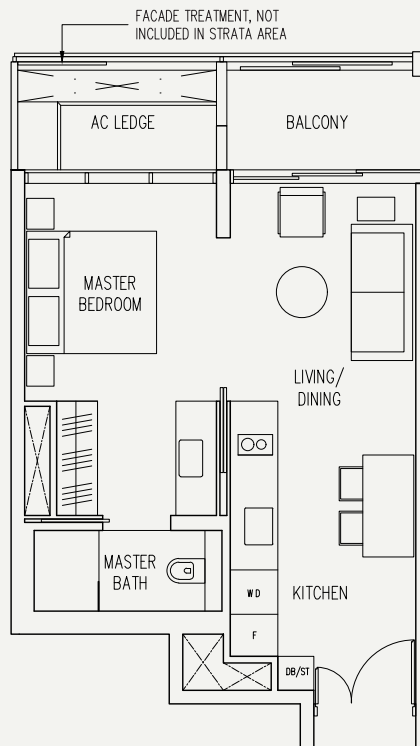

Area includes air-con (A/C) ledge, balcony and strata void area where applicable. Please refer to the key plan for orientation. The plans are subject to change as may be approved by relevant authorities. All floor plans are approximate measurements only and are subject to government re-survey. The balcony shall not be enclosed unless with the approved balcony screen. *Denotes different ceiling height.

1-Bedroom

Type A2

53 sqm / 570 sq ft
#02-08 to #08-08, #09-08*

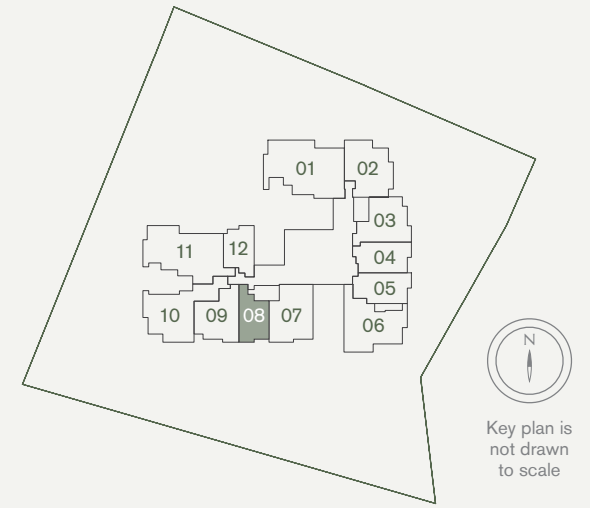

EVEN FLOOR

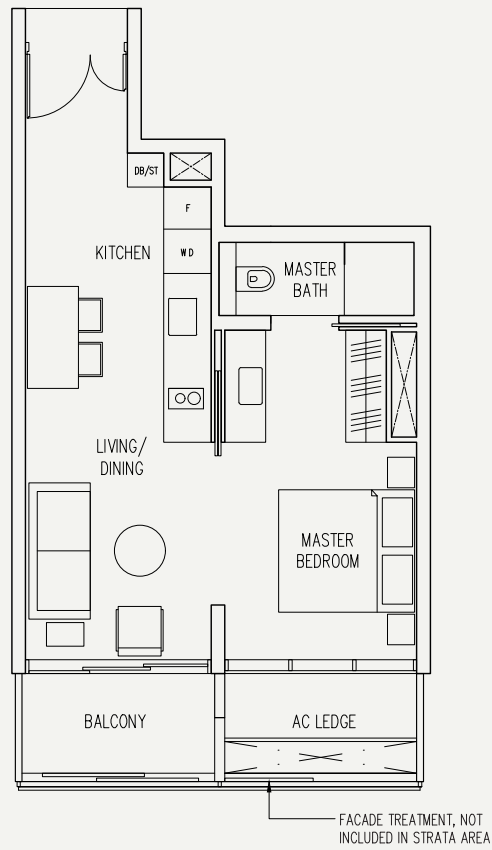

ODD FLOOR

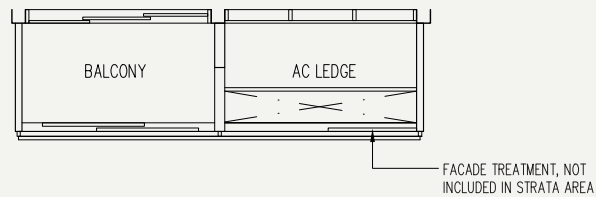

Area includes air-con (A/C) ledge, balcony and strata void area where applicable. Please refer to the key plan for orientation. The plans are subject to change as may be approved by relevant authorities. All floor plans are approximate measurements only and are subject to government re-survey. The balcony shall not be enclosed unless with the approved balcony screen. *Denotes different ceiling height.

1-Bedroom + Study

Type AS1

63 sqm / 678 sq ft
#02-04 to #09-04

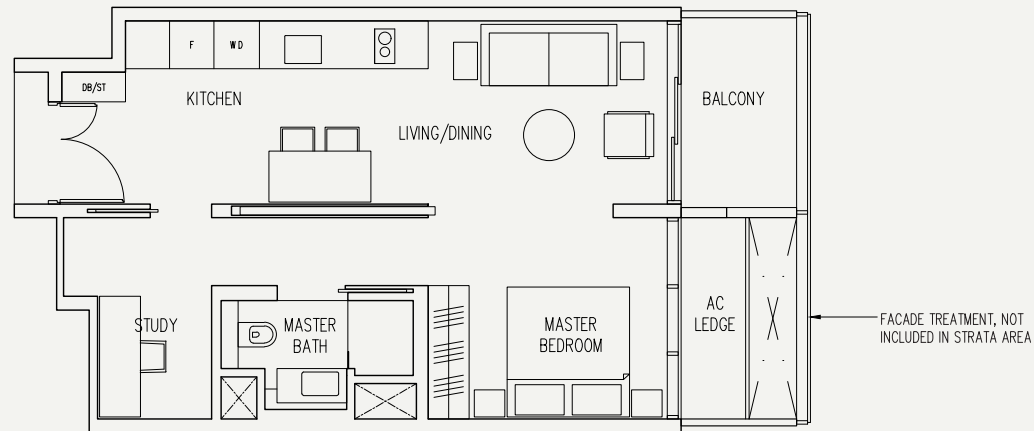
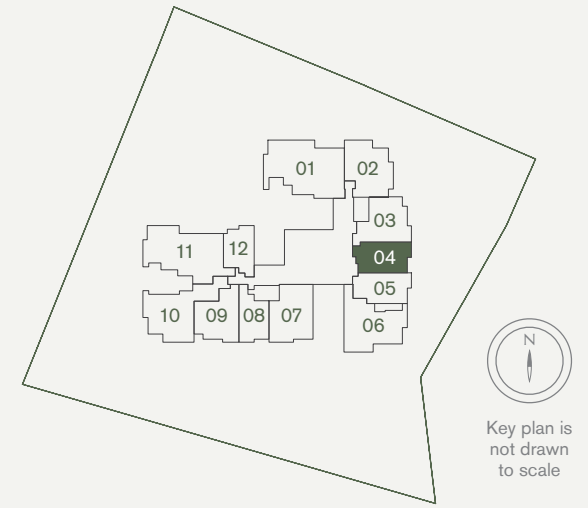

Area includes air-con (A/C) ledge, balcony and strata void area where applicable. Please refer to the key plan for orientation. The plans are subject to change as may be approved by relevant authorities. All floor plans are approximate measurements only and are subject to government re-survey. The balcony shall not be enclosed unless with the approved balcony screen. *Denotes different ceiling height.

1-Bedroom + Study

Type AS2

60 sqm / 646 sq ft
#02-05 to #09-05

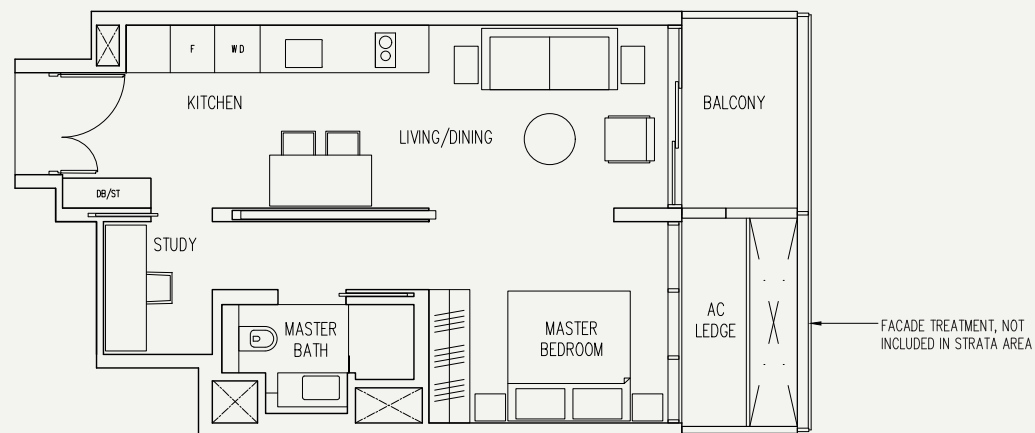
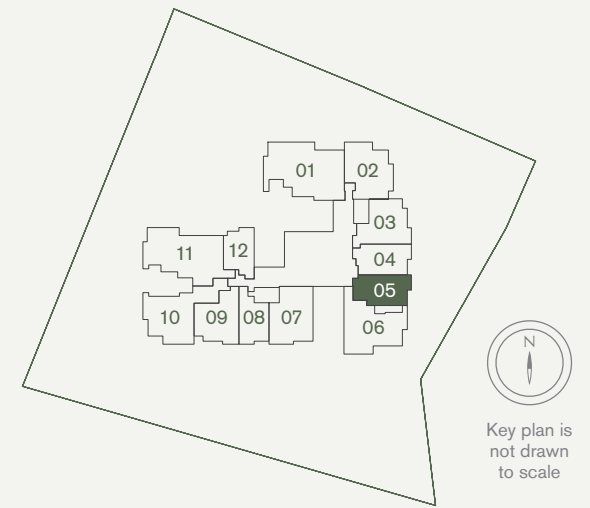

Area includes air-con (A/C) ledge, balcony and strata void area where applicable. Please refer to the key plan for orientation. The plans are subject to change as may be approved by relevant authorities. All floor plans are approximate measurements only and are subject to government re-survey. The balcony shall not be enclosed unless with the approved balcony screen. *Denotes different ceiling height.

2-Bedroom

Type B1(P)

104 sqm / 1,119 sq ft
#01-02

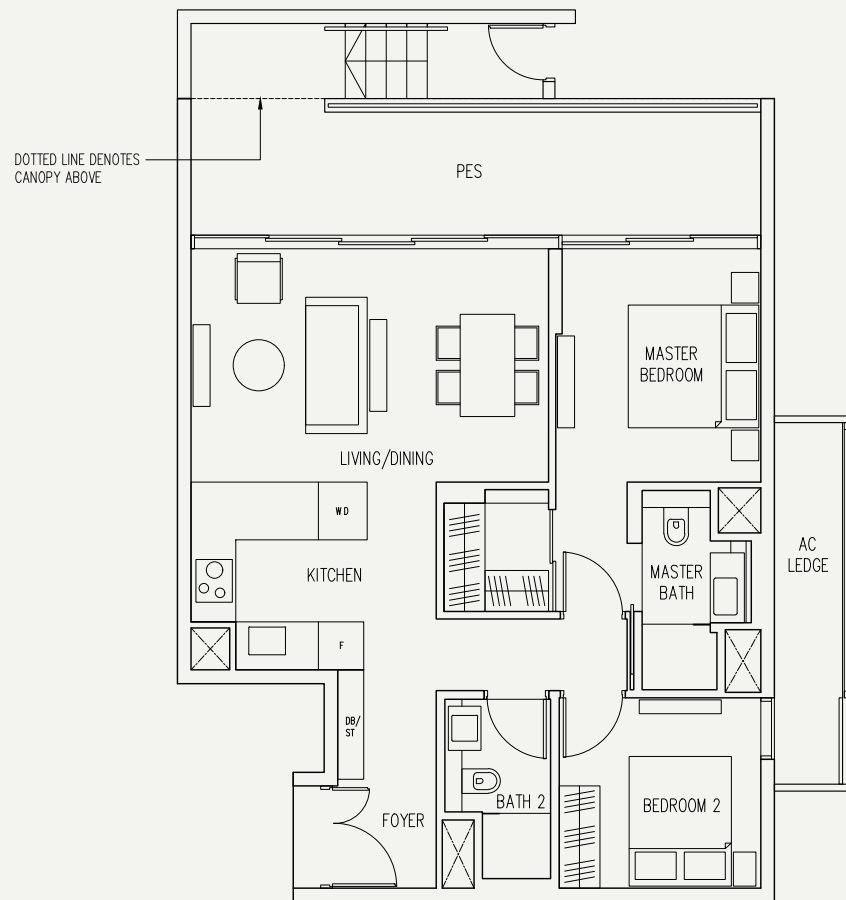
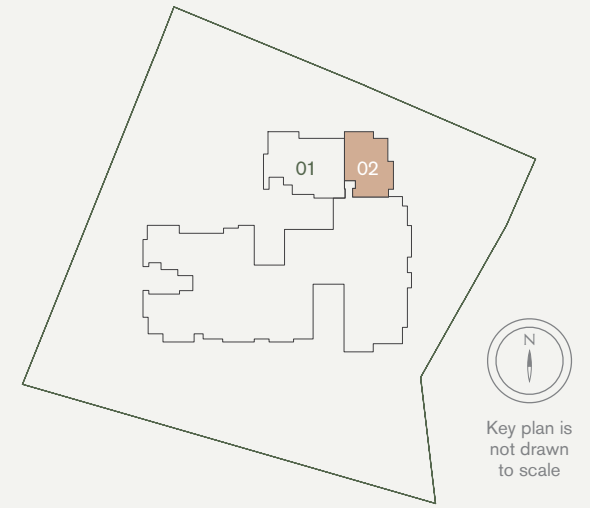

Area includes air-con (A/C) ledge, balcony and strata void area where applicable. Please refer to the key plan for orientation. The plans are subject to change as may be approved by relevant authorities. All floor plans are approximate measurements only and are subject to government re-survey. *Denotes different ceiling height.

2-Bedroom

Type B1

90 sqm / 969 sq ft
#02-02 to #08-02, #09-02*

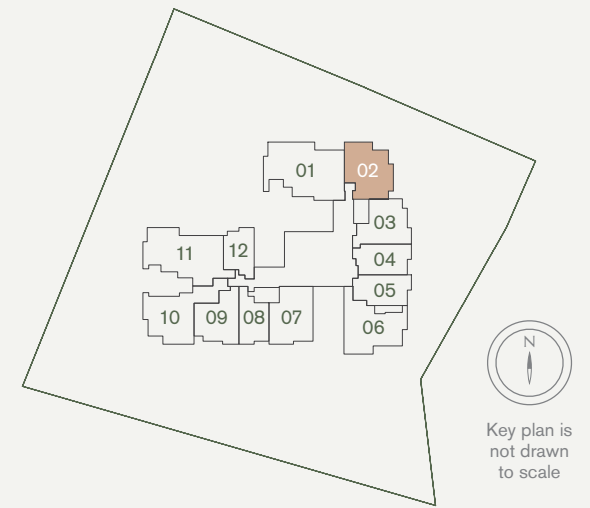

ODD FLOOR

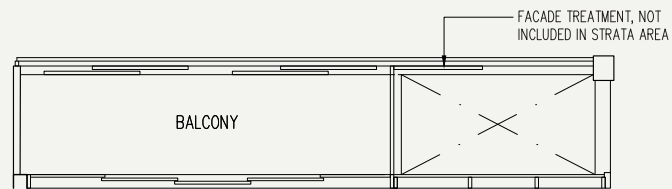

EVEN FLOOR

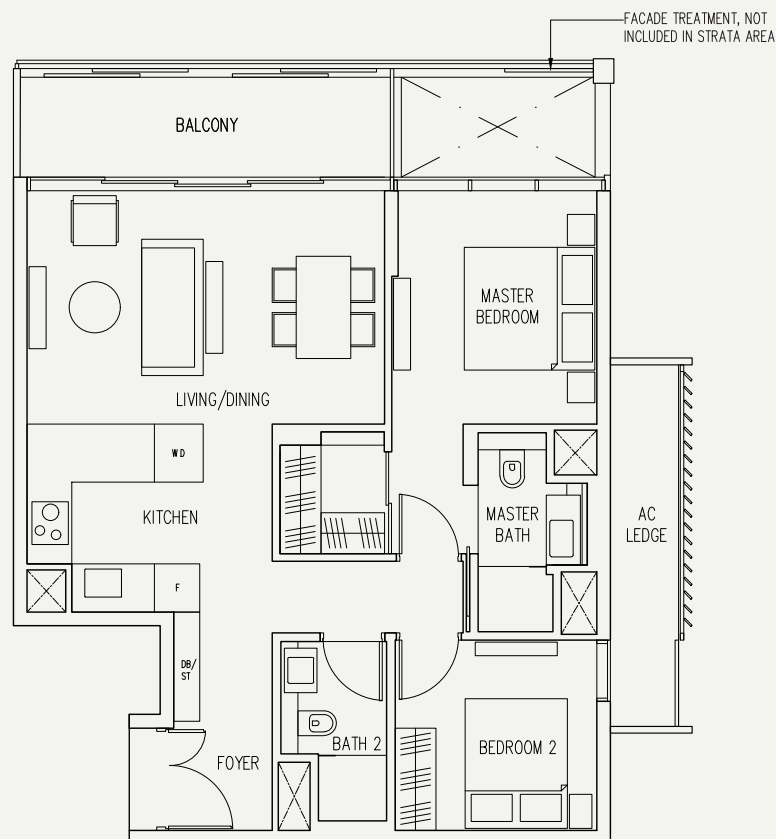

Area includes air-con (A/C) ledge, balcony and strata void area where applicable. Please refer to the key plan for orientation. The plans are subject to change as may be approved by relevant authorities. All floor plans are approximate measurements only and are subject to government re-survey. The balcony shall not be enclosed unless with the approved balcony screen. *Denotes different ceiling height.

2-Bedroom

Type B2

77 sqm / 829 sq ft
#02-03 to #09-03

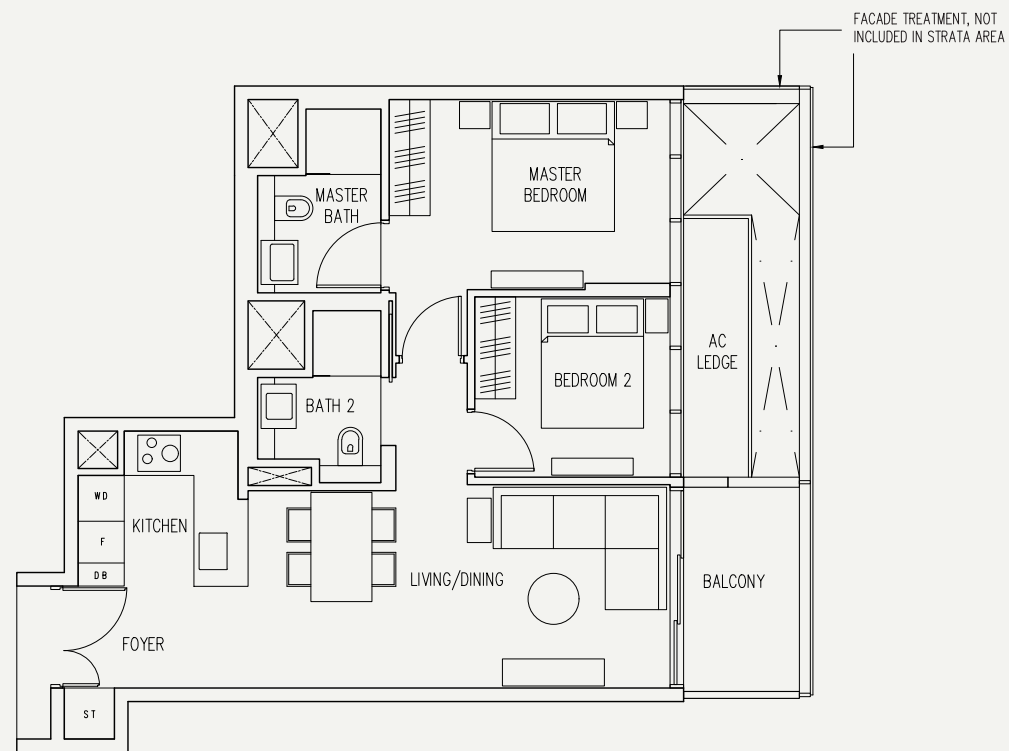
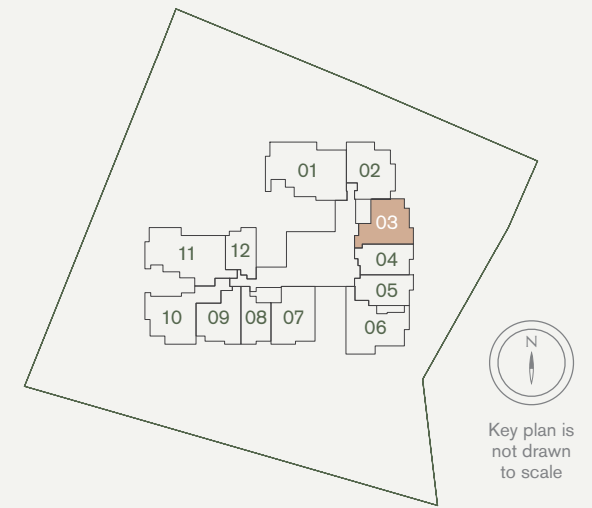

Area includes air-con (A/C) ledge, balcony and strata void area where applicable. Please refer to the key plan for orientation. The plans are subject to change as may be approved by relevant authorities. All floor plans are approximate measurements only and are subject to government re-survey. The balcony shall not be enclosed unless with the approved balcony screen. *Denotes different ceiling height.

2-Bedroom

Type B2A

75 sqm / 807 sq ft
#02-09 to #08-09, #09-09*

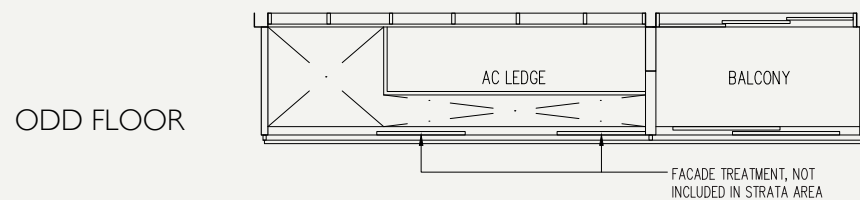
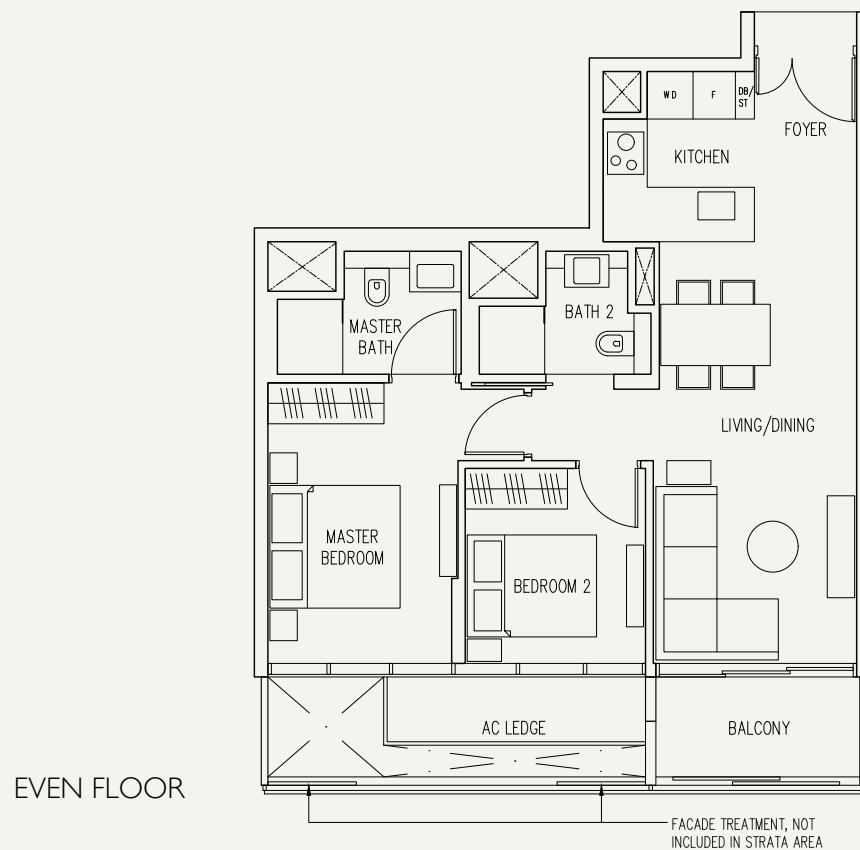
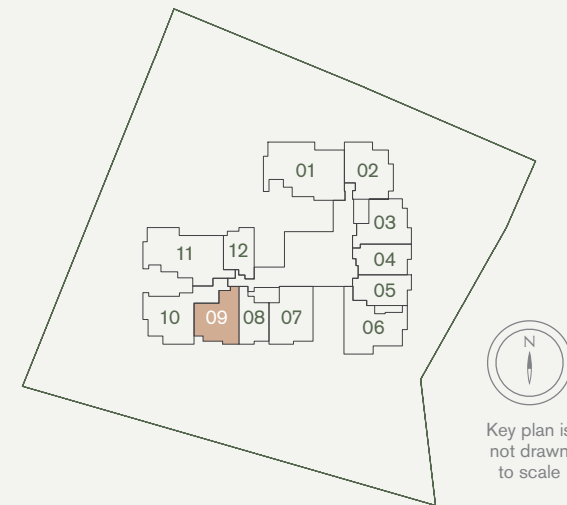

Area includes air-con (A/C) ledge, balcony and strata void area where applicable. Please refer to the key plan for orientation. The plans are subject to change as may be approved by relevant authorities. All floor plans are approximate measurements only and are subject to government re-survey. The balcony shall not be enclosed unless with the approved balcony screen. *Denotes different ceiling height.

2-Bedroom

Type B3

86 sqm / 926 sq ft
#02-07 to #08-07, #09-07*

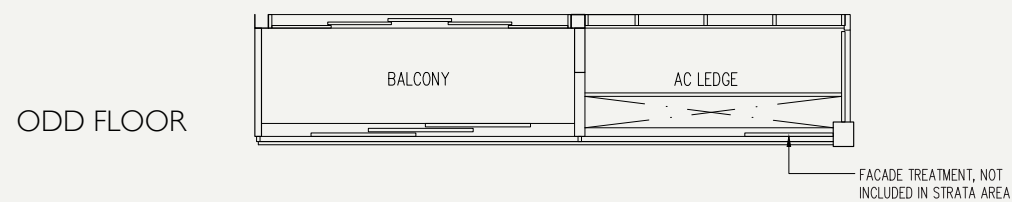
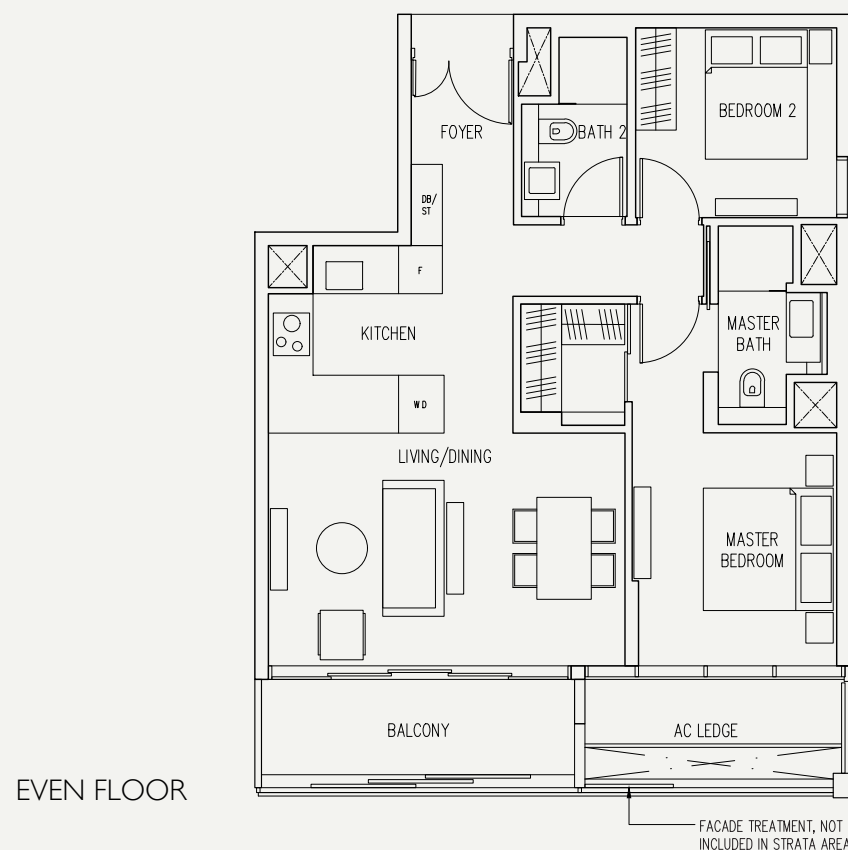
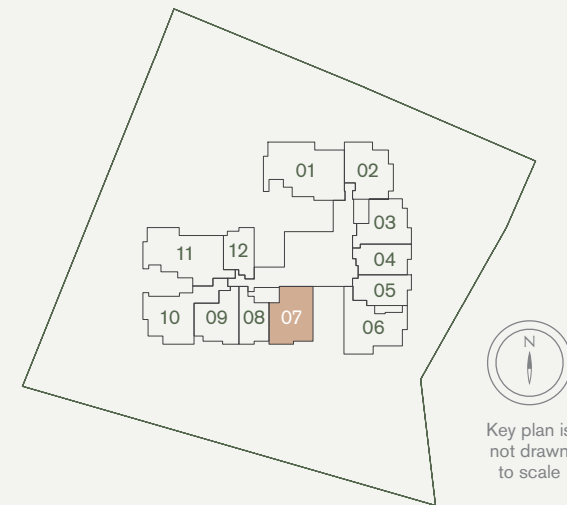

Area includes air-con (A/C) ledge, balcony and strata void area where applicable. Please refer to the key plan for orientation. The plans are subject to change as may be approved by relevant authorities. All floor plans are approximate measurements only and are subject to government re-survey. The balcony shall not be enclosed unless with the approved balcony screen. *Denotes different ceiling height.

2-Bedroom + Study

Type BS1

98 sqm / 1,055 sq ft
#02-06 to #09-06

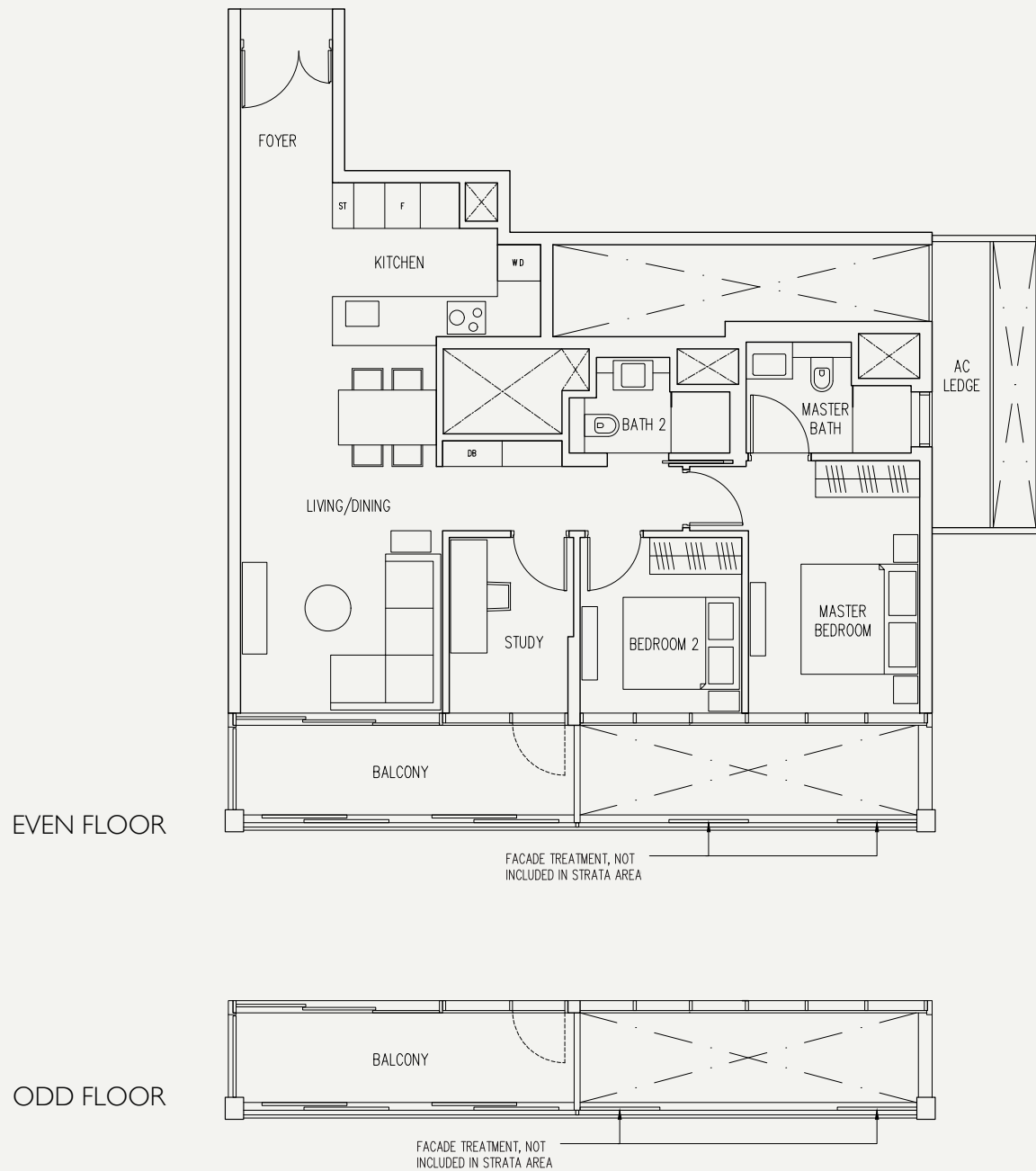
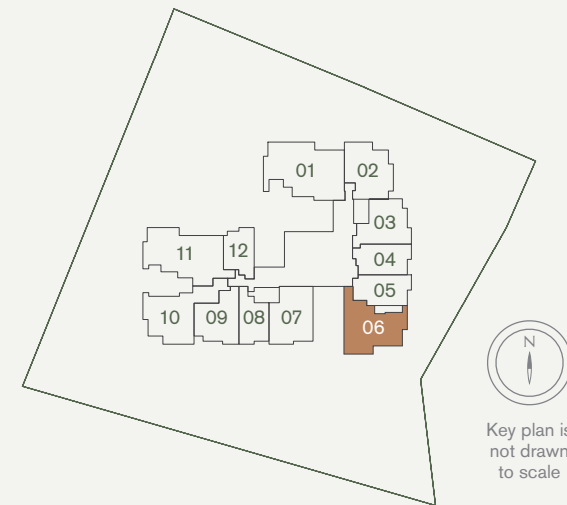

Area includes air-con (A/C) ledge, balcony and strata void area where applicable. Please refer to the key plan for orientation. The plans are subject to change as may be approved by relevant authorities. All floor plans are approximate measurements only and are subject to government re-survey. The balcony shall not be enclosed unless with the approved balcony screen. *Denotes different ceiling height.

2-Bedroom Deluxe

Type B4

103 sqm / 1,109 sq ft
#02-10 to #08-10, #09-10*

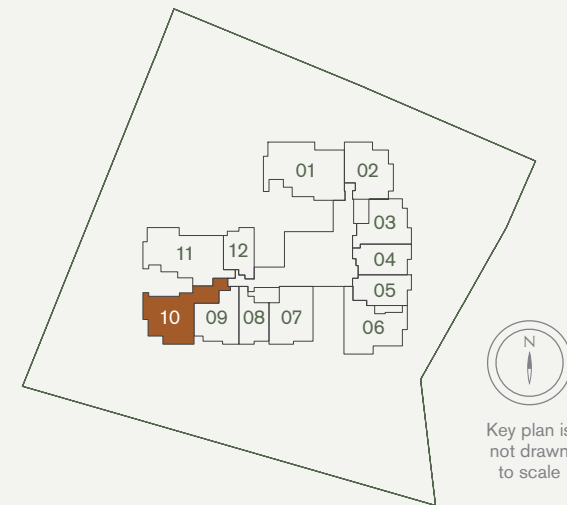

Key plan is not drawn to scale

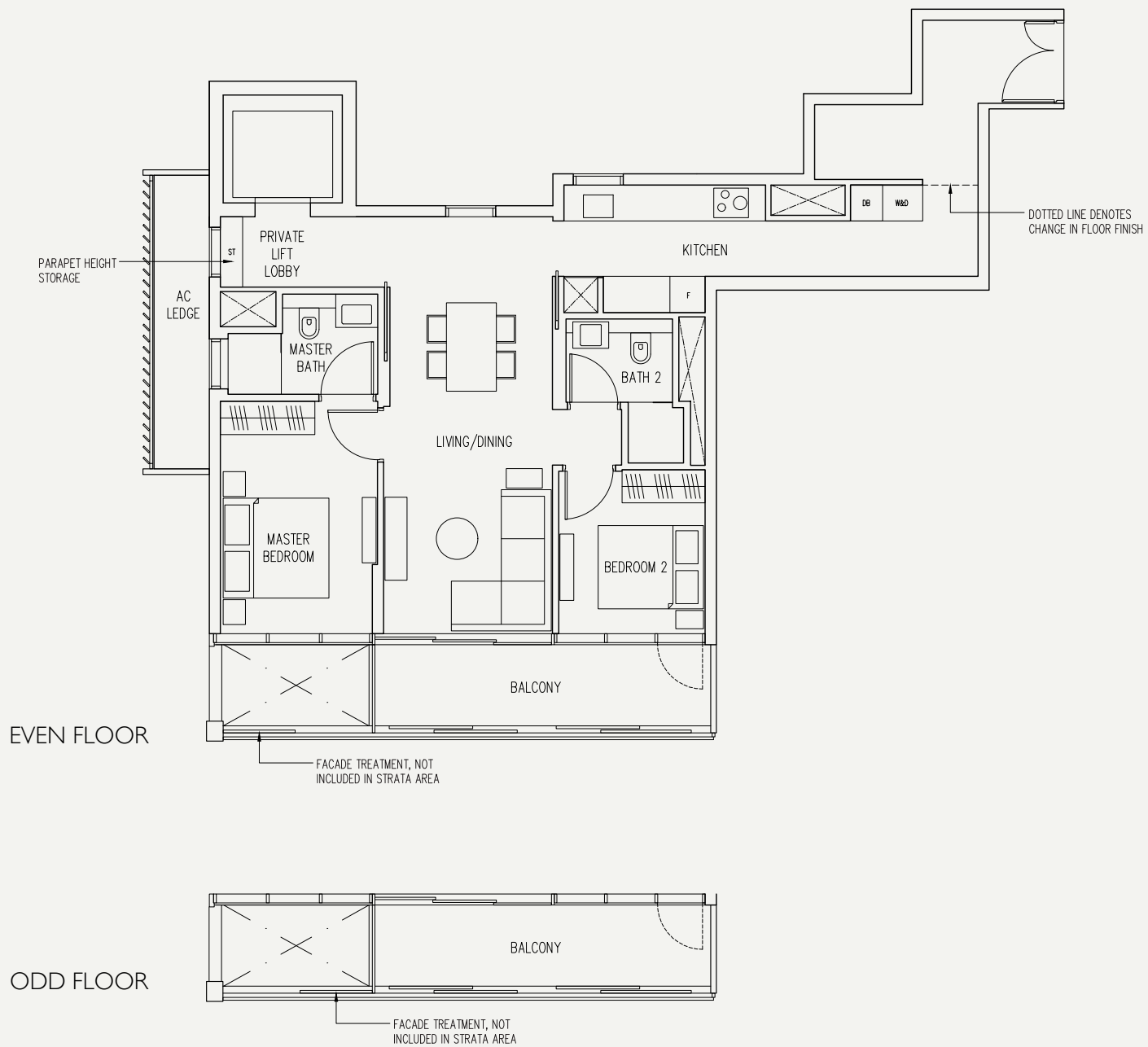

Area includes air-con (A/C) ledge, balcony and strata void area where applicable. Please refer to the key plan for orientation. The plans are subject to change as may be approved by relevant authorities. All floor plans are approximate measurements only and are subject to government re-survey. The balcony shall not be enclosed unless with the approved balcony screen. *Denotes different ceiling height.

3-Bedroom Deluxe

Type C1

131 sqm / 1,410 sq ft
#03-01, #05-01, #07-01, #09-01*

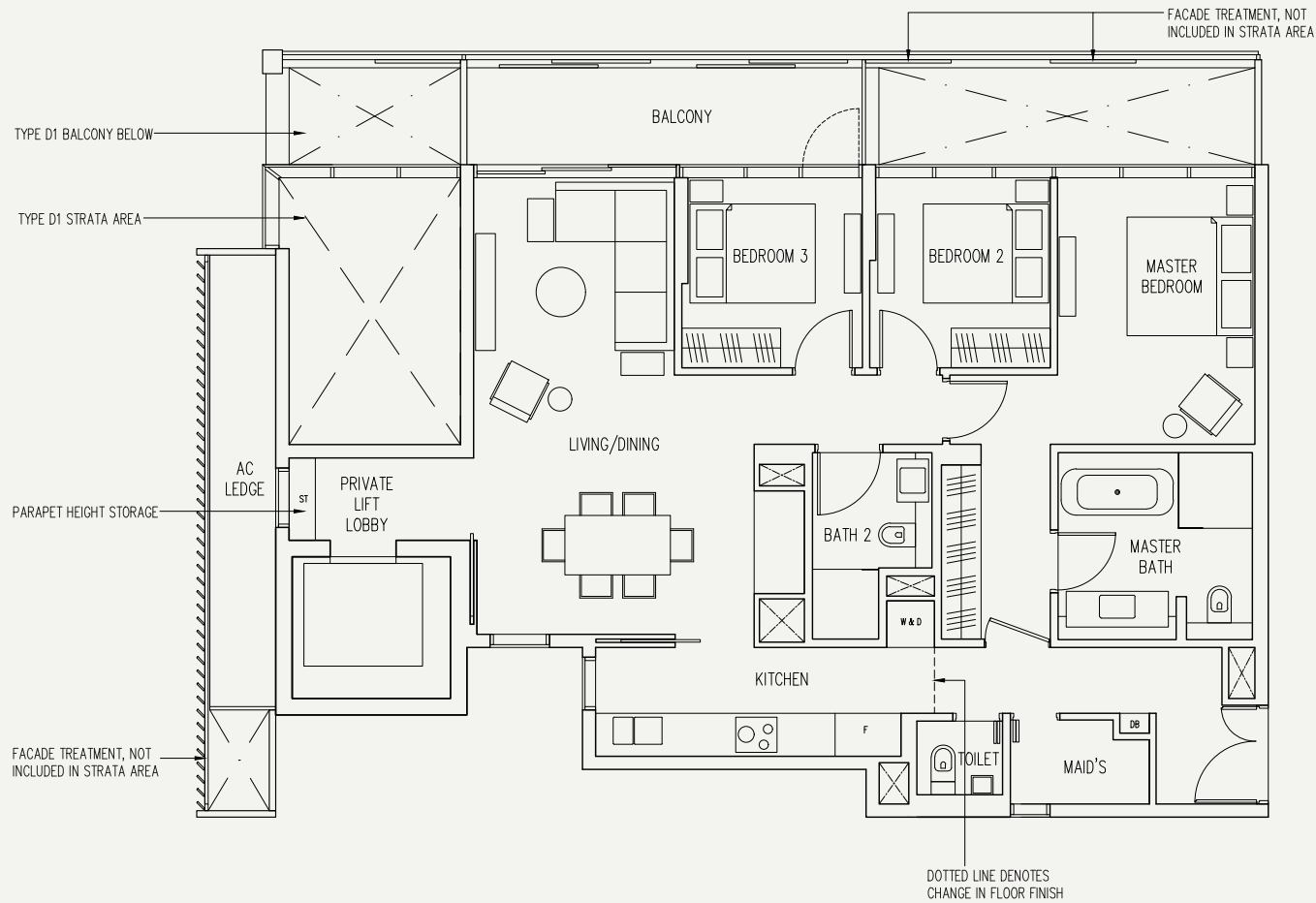
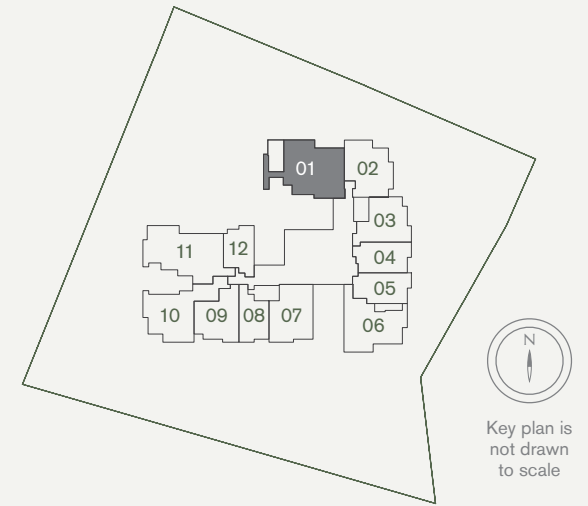

Area includes air-con (A/C) ledge, balcony and strata void area where applicable. Please refer to the key plan for orientation. The plans are subject to change as may be approved by relevant authorities. All floor plans are approximate measurements only and are subject to government re-survey. The balcony shall not be enclosed unless with the approved balcony screen. *Denotes different ceiling height.

3-Bedroom Deluxe

Type C2

137 sqm / 1,475 sq ft
#02-11 to #08-11, #09-11*, #10-11*

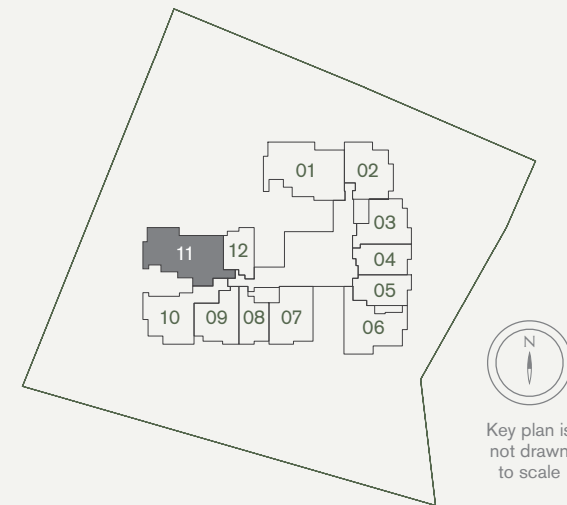

ODD FLOOR

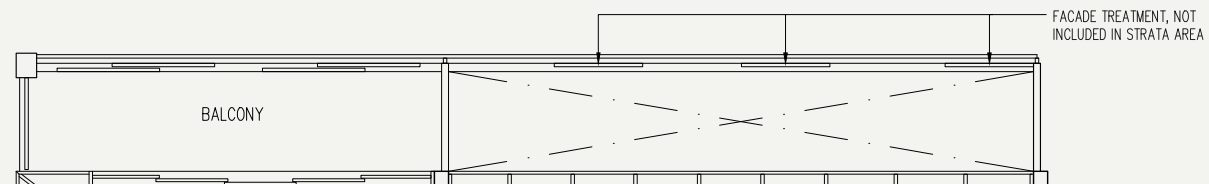

EVEN FLOOR

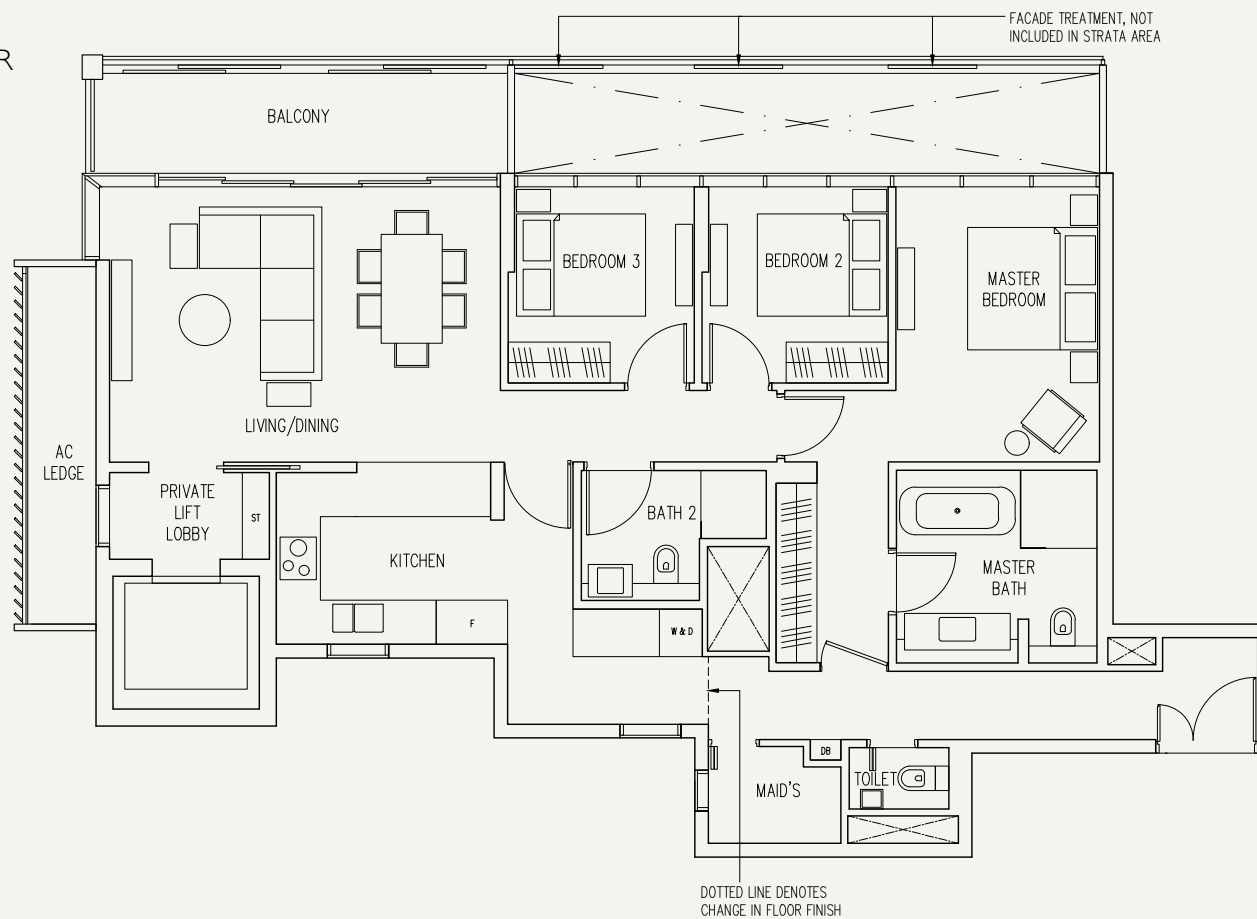

Area includes air-con (A/C) ledge, balcony and strata void area where applicable. Please refer to the key plan for orientation. The plans are subject to change as may be approved by relevant authorities. All floor plans are approximate measurements only and are subject to government re-survey. The balcony shall not be enclosed unless with the approved balcony screen. *Denotes different ceiling height.

3-Bedroom Deluxe

Type C3

123 sqm / 1,324 sq ft
#10-10

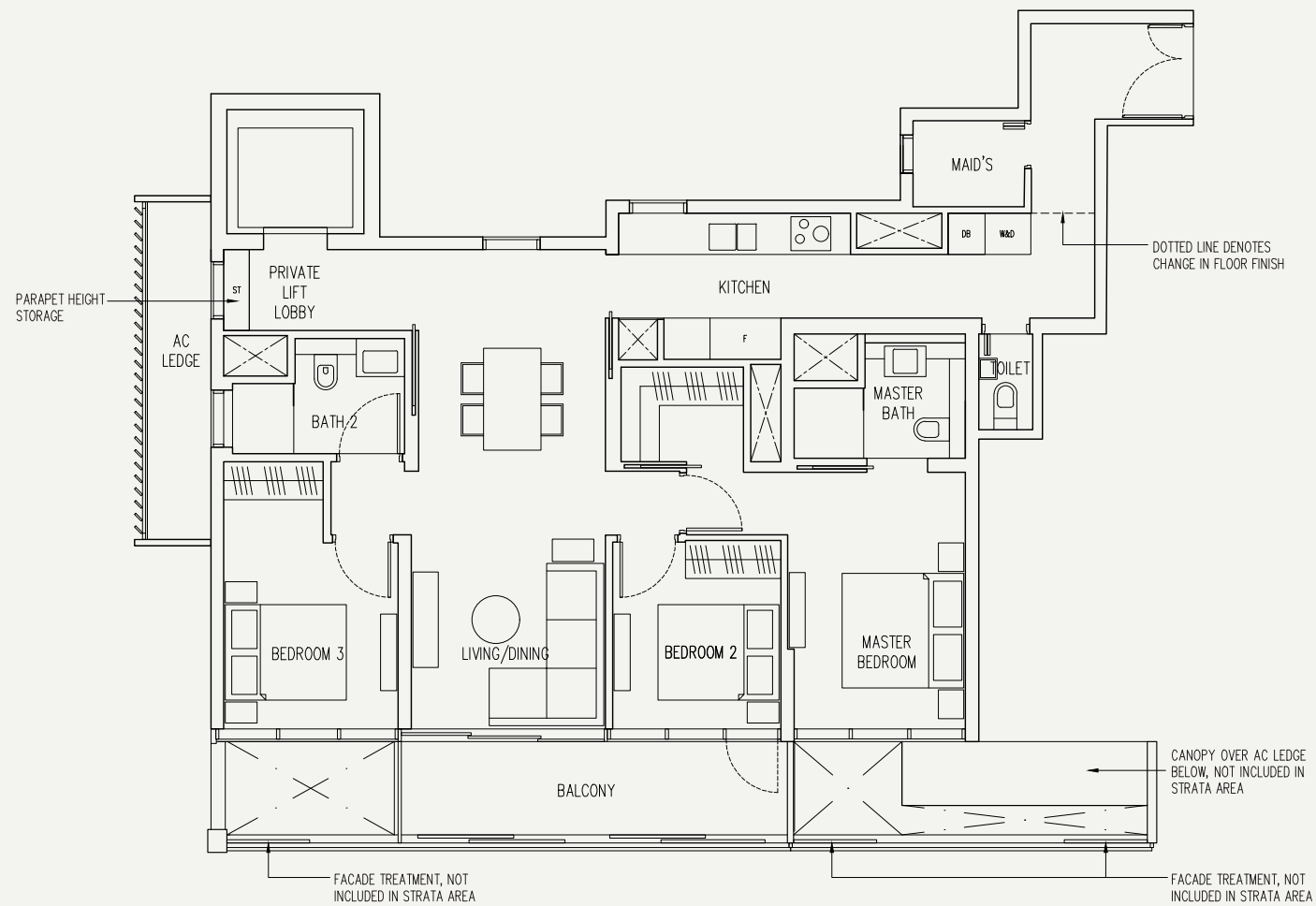
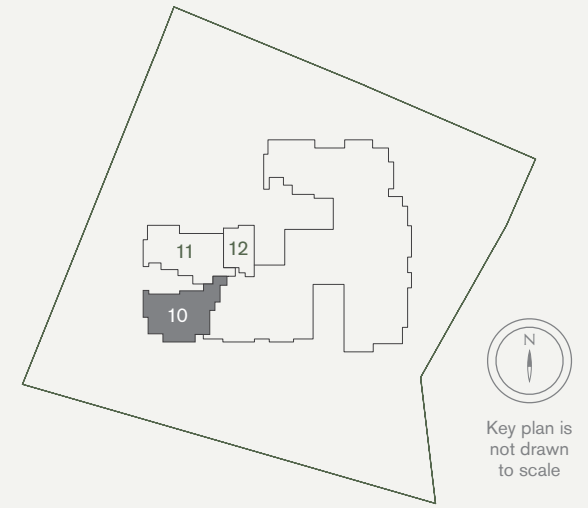

Area includes air-con (A/C) ledge, balcony and strata void area where applicable. Please refer to the key plan for orientation. The plans are subject to change as may be approved by relevant authorities. All floor plans are approximate measurements only and are subject to government re-survey. The balcony shall not be enclosed unless with the approved balcony screen. *Denotes different ceiling height.

3-Bedroom Deluxe

Type D1(P) 170 sqm / 1,830 sq ft
#01-01

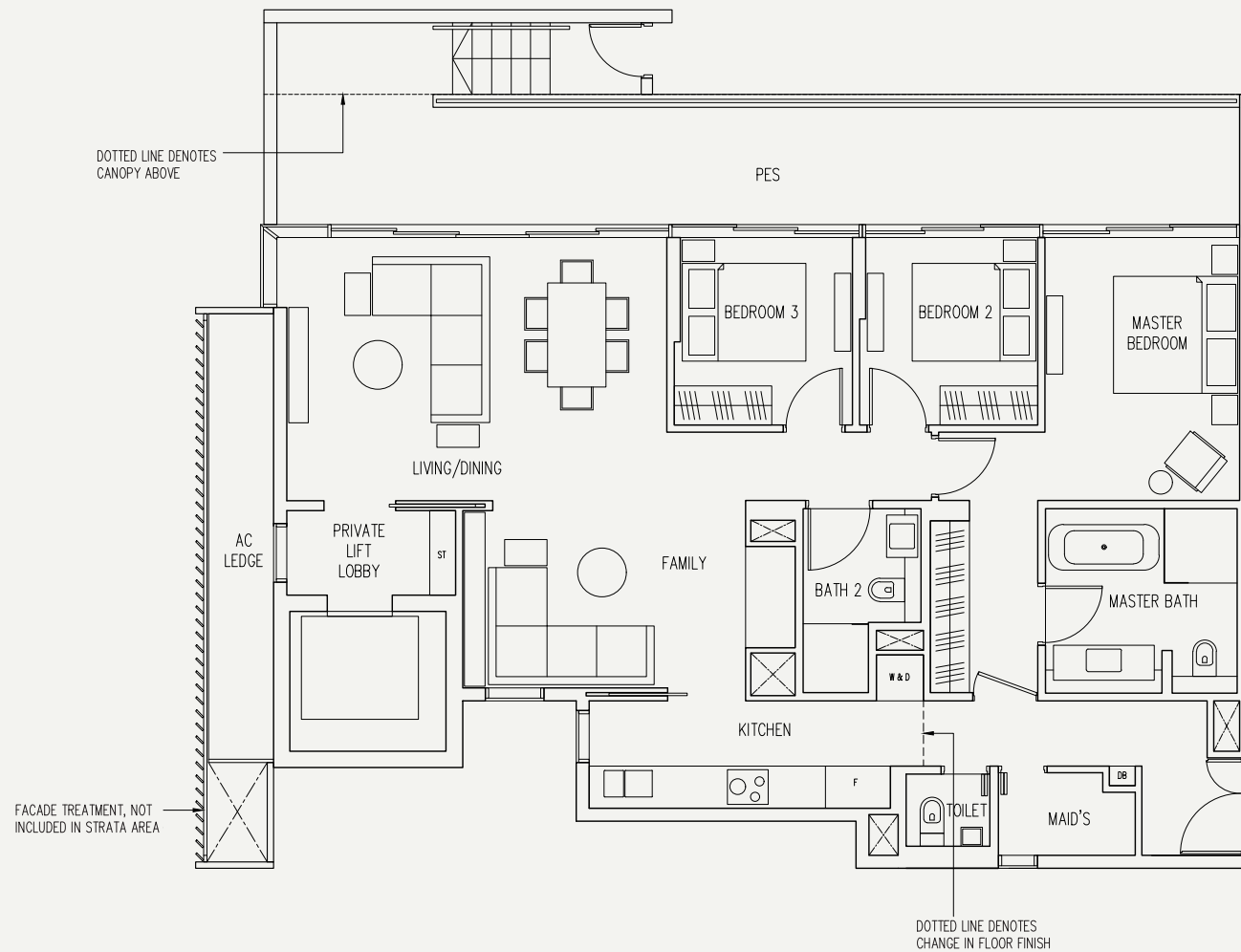
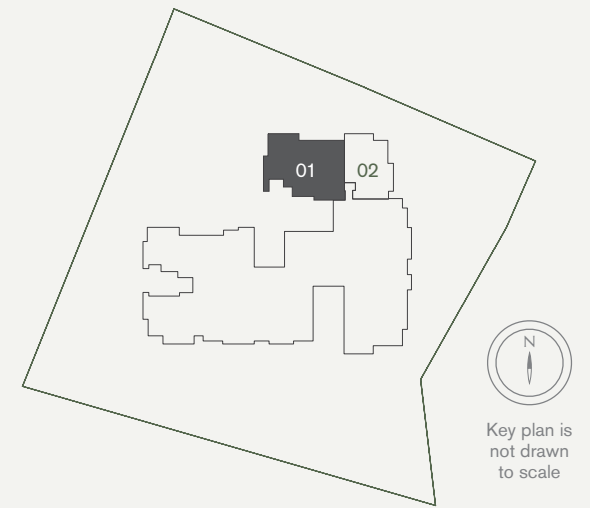

Area includes air-con (A/C) ledge, balcony and strata void area where applicable. Please refer to the key plan for orientation. The plans are subject to change as may be approved by relevant authorities. All floor plans are approximate measurements only and are subject to government re-survey. The balcony shall not be enclosed unless with the approved balcony screen. *Denotes different ceiling height.

3-Bedroom Deluxe

Type D1

161 sqm / 1,733 sq ft
 #02-01, #04-01, #06-01, #08-01*

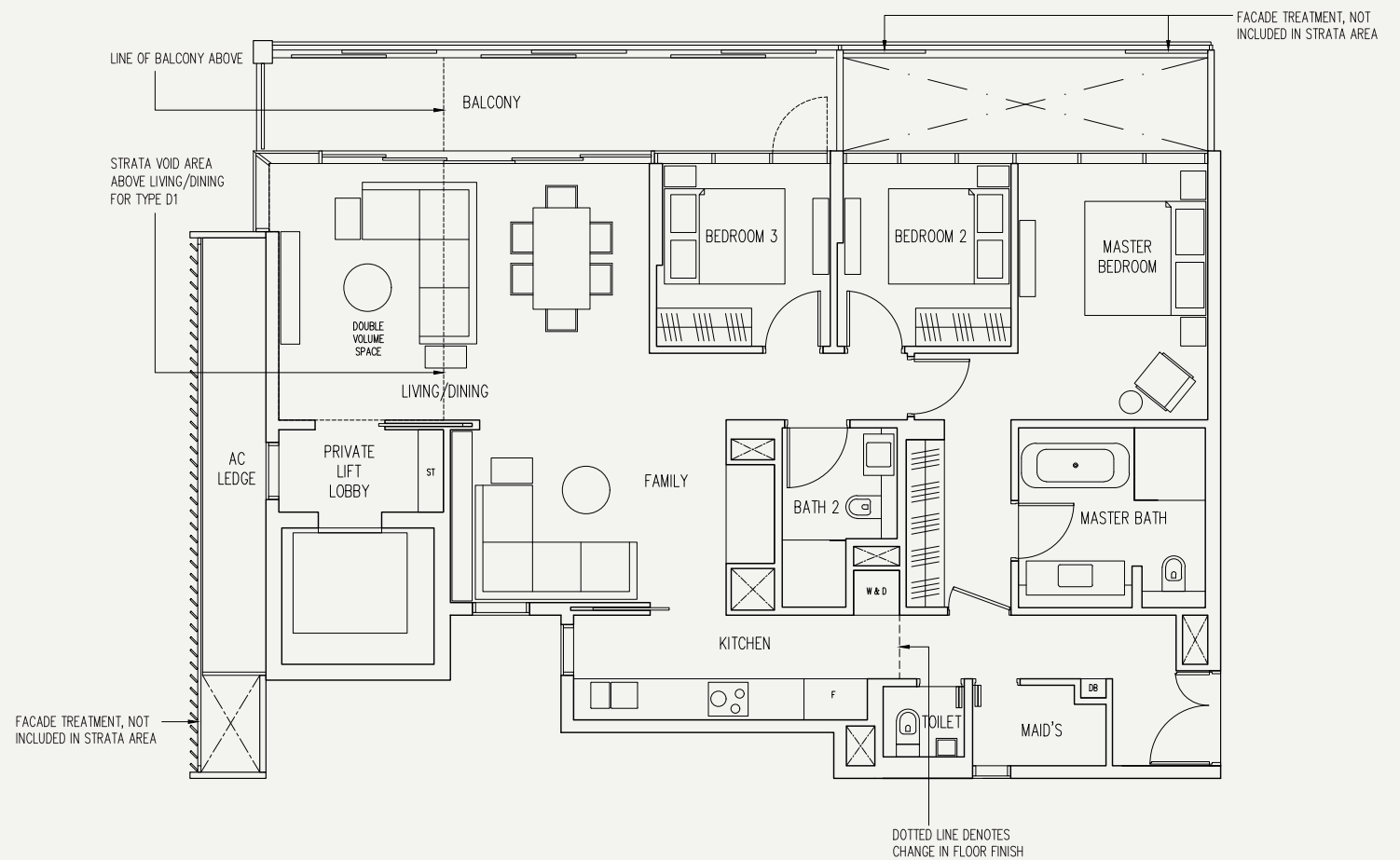
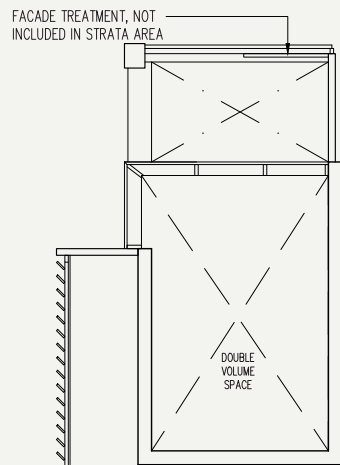
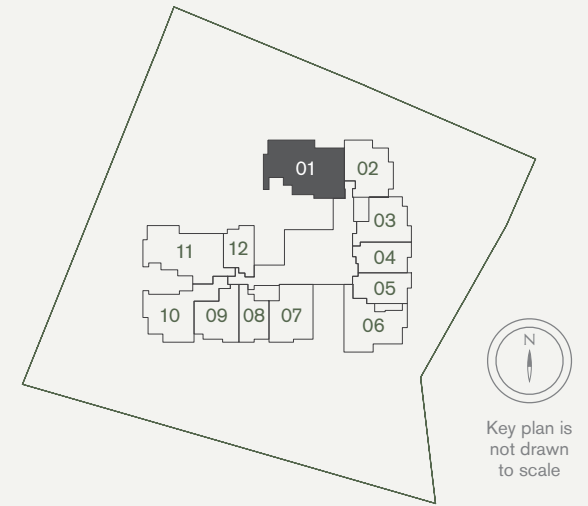

Area includes air-con (A/C) ledge, balcony and strata void area where applicable. Please refer to the key plan for orientation. The plans are subject to change as may be approved by relevant authorities. All floor plans are approximate measurements only and are subject to government re-survey. The balcony shall not be enclosed unless with the approved balcony screen. *Denotes different ceiling height.